



US007958594B2

(12) **United States Patent**
Cunningham

(10) **Patent No.:** **US 7,958,594 B2**

(45) **Date of Patent:** **Jun. 14, 2011**

(54) **CENTRAL VACUUM CLEANER**
CROSS-CONTROLS

(75) Inventor: **J. Vern Cunningham**, Aurora (CA)

(73) Assignee: **Cube Investments Limited**, Aurora (CA)

3,626,545 A	12/1971	Sparrow
3,628,769 A	12/1971	Lee
3,661,356 A	5/1972	Tucker
3,663,845 A	5/1972	Apstein
3,676,986 A	7/1972	Reiling
3,826,464 A	7/1974	Berghofer
3,855,665 A	12/1974	Schwartz
3,965,526 A	6/1976	Doubleday

(Continued)

(*) Notice: Subject to any disclaimer, the term of this patent is extended or adjusted under 35 U.S.C. 154(b) by 1209 days.

FOREIGN PATENT DOCUMENTS

EP 0192469 8/1986

(Continued)

(21) Appl. No.: **11/543,954**

(22) Filed: **Oct. 6, 2006**

OTHER PUBLICATIONS

(65) **Prior Publication Data**

US 2007/0079467 A1 Apr. 12, 2007

Gale Group, New Central Vacuum Breaks Home Automation Barrier, Feb. 26, 2002, http://www.findarticles.com/cf_dls/m0EIN/2002Feb26/83293317/p1/article.html.

(Continued)

Related U.S. Application Data

(60) Provisional application No. 60/784,770, filed on Mar. 23, 2006, provisional application No. 60/724,290, filed on Oct. 7, 2005, provisional application No. 60/777,528, filed on Mar. 1, 2006.

Primary Examiner — David A Redding

(74) *Attorney, Agent, or Firm* — Dowell & Dowell, P.C.

(51) **Int. Cl.**

A47L 5/38 (2006.01)

(52) **U.S. Cl.** **15/301**; 15/319; 15/339

(58) **Field of Classification Search** 15/301, 15/319, 339; *A47L 5/38*

See application file for complete search history.

(57)

ABSTRACT

A vacuum cleaning system for use in a structure. System has receiver adapted to receive communication that an appliance has been activated, and a control circuit adapted to control the central vacuum cleaning system upon receipt of a communication at the receiver that the appliance has been activated. Example appliances include doorbell, telephone or ERV. System may have a communication module that communicates with corresponding appliance communication module. The system communication module may transmit communications to the appliance communication module. Alternatively, the appliance communication module may transmit communications to the system communications module. The modules may both receive and transmit. Preferably, communications between modules are radio frequency (RF) wireless, however wired communications, where wiring is possible or available, are also suitable.

(56) **References Cited**

U.S. PATENT DOCUMENTS

1,601,531 A	9/1926	Jeannin
1,883,288 A	10/1932	Zubaty
3,088,484 A	5/1963	Marsh
3,357,039 A	12/1967	Hayward
3,382,524 A	5/1968	Sandstrom
3,477,689 A	11/1969	Berghoefter
3,483,503 A	12/1969	Pardiso
3,565,103 A	2/1971	Maselek
3,570,809 A	3/1971	Stuy

12 Claims, 12 Drawing Sheets

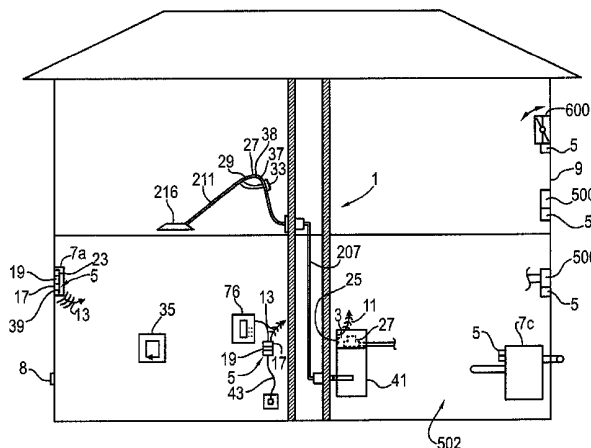

U.S. PATENT DOCUMENTS		
3,989,311 A	11/1976	Debrey
4,056,334 A	11/1977	Fortune
4,070,586 A	1/1978	Breslin
4,111,615 A	9/1978	Watanabe
4,114,557 A	9/1978	De Brey
4,175,892 A	11/1979	De Brey
4,225,272 A	9/1980	Palmovist
4,227,258 A	10/1980	Root et al.
4,246,675 A	1/1981	Costanzo
4,300,262 A	11/1981	Rodowsky, Jr. et al.
4,336,427 A	6/1982	Lindsay
4,368,348 A	1/1983	Eichelberger et al.
4,369,543 A	1/1983	Chen et al.
4,370,776 A	2/1983	Kullik
4,443,906 A	4/1984	Tucker et al.
4,473,923 A	10/1984	Neroni et al.
4,490,575 A	12/1984	Kutnyak
4,494,270 A	1/1985	Ritzau et al.
4,513,469 A	4/1985	Godfrey et al.
4,531,796 A	7/1985	Gansert et al.
4,536,674 A	8/1985	Schmidt
4,591,368 A	5/1986	MacDuff
4,611,365 A	9/1986	Komatsu et al.
4,654,924 A	4/1987	Getz et al.
4,664,457 A	5/1987	Suchy
4,680,827 A	7/1987	Hummel
4,683,515 A	7/1987	Beihoff et al.
4,688,596 A	8/1987	Liebmann et al.
4,693,324 A	9/1987	Choiniere et al.
4,731,545 A	3/1988	Lerner et al.
4,757,574 A	7/1988	Sumerau
4,766,628 A	8/1988	Walker
4,791,700 A	12/1988	Bigley et al.
4,829,625 A	5/1989	Wang
4,829,626 A	5/1989	Harkonen et al.
4,854,887 A	8/1989	Blandin
4,881,909 A	11/1989	Blackman
4,883,982 A	11/1989	Forbes et al.
D315,043 S	2/1991	Hayden
4,991,253 A	2/1991	Rechsteiner
5,033,151 A	7/1991	Kraft et al.
5,067,394 A	11/1991	Cavallero
5,068,555 A	11/1991	Oberdorfer-Bogel
5,107,565 A	4/1992	Chun
5,109,568 A	5/1992	Rohn et al.
5,111,841 A	5/1992	Houston
5,120,983 A	6/1992	Samaan
5,125,125 A	6/1992	Barsacq
D333,023 S	2/1993	Herron, Jr.
5,185,705 A	2/1993	Farrington
D334,447 S	3/1993	Rohn
5,191,673 A	3/1993	Damizet
5,207,498 A	5/1993	Lawrence et al.
5,244,409 A	9/1993	Guss et al.
5,255,409 A	10/1993	Fujiwara et al.
5,263,502 A	11/1993	Dick
5,265,305 A	11/1993	Kraft et al.
5,274,578 A	12/1993	Noeth et al.
5,274,878 A	1/1994	Radabaugh et al.
5,276,939 A	1/1994	Uenishi
5,277,468 A	1/1994	Blatt et al.
5,298,821 A	3/1994	Michel
5,301,385 A	4/1994	Abe et al.
5,311,639 A	5/1994	Boshler
5,343,590 A	9/1994	Radabaugh
5,347,186 A	9/1994	Konotchick
5,349,146 A	9/1994	Radabaugh
5,353,468 A	10/1994	Yap et al.
5,363,534 A	11/1994	Dekker et al.
5,379,796 A	1/1995	Wang
5,391,064 A	2/1995	Lopez
5,404,612 A	4/1995	Ishikawa
5,409,398 A	4/1995	Chadbourne et al.
5,448,827 A	9/1995	Ward
D364,014 S	11/1995	Langeland et al.
5,479,676 A	1/1996	Martin et al.
5,504,971 A	4/1996	McCormick
5,512,883 A	4/1996	Lane, Jr.
5,515,572 A	5/1996	Hoekstra et al.
5,525,842 A	6/1996	Leiningner
5,542,146 A	8/1996	Hoekstra et al.
5,554,049 A	9/1996	Reynolds
5,560,076 A	10/1996	Leung
5,568,374 A	10/1996	Lindeboom et al.
5,572,767 A	11/1996	Ishikawa
5,578,795 A	11/1996	Ward
5,606,767 A	3/1997	Crienjak et al.
5,655,884 A	8/1997	Rose
5,698,957 A	12/1997	Sowada
5,713,656 A	2/1998	Lin
5,722,110 A	3/1998	McIntyre et al.
5,737,797 A	4/1998	Rittmueller et al.
5,737,798 A	4/1998	Moren et al.
5,740,581 A	4/1998	Harrelson, II
5,740,582 A	4/1998	Harrelson, II
5,747,973 A	5/1998	Robitaille et al.
5,753,989 A	5/1998	Syverson et al.
5,813,085 A	9/1998	Fritz et al.
5,815,883 A	10/1998	Stein et al.
5,815,884 A	10/1998	Imamura et al.
5,816,685 A	10/1998	Hou
5,850,665 A	12/1998	Bousset
5,871,152 A	2/1999	Saney
D406,422 S	3/1999	Burchard et al.
5,893,194 A	4/1999	Karmel
5,896,618 A	4/1999	Woo et al.
5,917,428 A	6/1999	Discenzo et al.
5,918,728 A	7/1999	Syverson
5,924,163 A	7/1999	Burns, Jr.
5,924,164 A	7/1999	Lindsay, Jr.
5,926,908 A	7/1999	Lindsay, Jr.
5,926,909 A	7/1999	McGee
5,938,061 A	8/1999	Ward et al.
5,945,749 A	8/1999	Li
5,983,443 A	11/1999	Redding
5,987,697 A	11/1999	Song et al.
6,011,334 A	1/2000	Roland
6,029,309 A	2/2000	Imamura
6,033,082 A	3/2000	Lin
6,049,143 A	4/2000	Simpson et al.
6,101,667 A	8/2000	Ishikawa
D431,335 S	9/2000	Mehaffey et al.
6,169,258 B1	1/2001	Roney et al.
6,206,181 B1	3/2001	Syverson
6,218,798 B1	4/2001	Price et al.
6,232,696 B1	5/2001	Kim et al.
6,239,576 B1	5/2001	Breslin et al.
6,244,427 B1	6/2001	Syverson
6,253,414 B1	7/2001	Bradd et al.
6,256,833 B1	7/2001	Steinberg
6,323,570 B1	11/2001	Nishimura et al.
6,336,825 B1	1/2002	Seefried
6,425,293 B1	7/2002	Woodroffe et al.
6,459,056 B1	10/2002	Graham
6,463,368 B1	10/2002	Feiten et al.
6,546,814 B1	4/2003	Choe et al.
6,628,019 B2	9/2003	Carroll
6,658,325 B2	12/2003	Zweig
6,685,491 B2	2/2004	Gergek
6,690,804 B2	2/2004	Everett
D494,332 S	8/2004	Schroeter
D494,333 S	8/2004	Schroeter
6,779,228 B2	8/2004	Plomteux et al.
6,791,205 B2	9/2004	Woodbridge
6,817,058 B1	11/2004	Harrelson, II
6,822,353 B2	11/2004	Koga et al.
6,864,594 B2	3/2005	Seki
6,900,565 B2	5/2005	Preston
6,975,043 B2	12/2005	Schumacher et al.
6,975,993 B1	12/2005	Lin
7,051,398 B2	5/2006	Smith et al.
7,080,425 B2	7/2006	Smith et al.
7,114,216 B2	10/2006	Stephens et al.
7,122,921 B2	10/2006	Hall et al.
7,237,298 B2	7/2007	Reindle et al.
7,269,877 B2	9/2007	Tondra et al.
7,328,479 B2	2/2008	Willenbring

7,331,083	B2	2/2008	Overvaag et al.
7,342,372	B2	3/2008	Jonsson et al.
7,363,679	B2	4/2008	Zimmerle et al.
7,403,360	B2	7/2008	Cunningham et al.
7,406,744	B2	8/2008	Bruneau
2002/0001190	A1	1/2002	Everett
2002/0127916	A1	9/2002	Zhang
2002/0152576	A1	10/2002	Murray et al.
2003/0044243	A1	3/2003	Tisdale
2003/0140443	A1	7/2003	Najm
2003/0196293	A1	10/2003	Ruff
2004/0031506	A1	2/2004	Tsai
2004/0049868	A1	3/2004	Ng
2004/0144633	A1	7/2004	Gordon et al.
2004/0150271	A1	8/2004	Koga et al.
2004/0172782	A1	9/2004	Smith et al.
2004/0177468	A1	9/2004	Smith et al.
2004/0231090	A1	11/2004	Kushida et al.
2004/0261211	A1	12/2004	Overvaag et al.
2005/0022329	A1	2/2005	Harman et al.
2005/0022337	A1	2/2005	Roney et al.
2005/0166351	A1	8/2005	Cunningham et al.
2005/0236012	A1	10/2005	Josefsson et al.
2005/0245194	A1	11/2005	Hayes et al.
2005/0254185	A1	11/2005	Cunningham
2007/0283521	A1	12/2007	Foster et al.
2008/0066252	A1	3/2008	Herron, Jr.
2008/0222836	A1*	9/2008	Cunningham 15/314
2008/0301903	A1	12/2008	Cunningham et al.

FOREIGN PATENT DOCUMENTS

EP	0347223	12/1989
EP	0552978 A2	1/1993
EP	0499235 B1	9/1995
EP	0711023 A2	5/1996
EP	0773619 A1	5/1997
GB	2281507	3/1995
GB	2288115	10/1995
JP	53058160 A2	5/1978
JP	53128158 A2	11/1978
JP	64-049526	2/1989
JP	2-152420	6/1990
JP	2-152419	12/1990
JP	4-017830	1/1992
JP	5-003839	1/1993
JP	5-317213	3/1993
JP	06277167 A2	10/1994
JP	7-095944	11/1995
JP	07322980	12/1995
JP	8-240329	9/1996
JP	9-149871	10/1997
JP	2009-058919	9/1998
JP	2000116577 A2	4/2000
JP	2001137158 A2	5/2001
JP	2002-078656	3/2002
JP	2002320577	5/2002
JP	2005-102465	4/2005
WO	9737423	10/1997
WO	WO9741631	11/1997
WO	98/35160	8/1998

WO	99/09875	3/1999
WO	9956606	11/1999
WO	WO0064323 A1	11/2000
WO	2005/031169	4/2005
WO	2007/017057	2/2007

OTHER PUBLICATIONS

Audioetcetera, Wireless Remote Control for Filtex Central Vacuum Systems, M&S Systems, date unknown, <http://www.audio-etcetera.com/prod.itml/icOid/135540>.

Central Vacuum Systems Owners Guide, M&S Systems, date unknown, Dallas, Texas.

Japan Patent Office computer translation of publication No. JP2000116577A2, printed Jan. 19, 2005, pp. 21.

Japan Patent Office computer translation of publication No. JP2001137158A2, printed Jan. 19, 2005, pp. 42.

Japan Patent Office computer translation of publication No. JP06277167A2, printed Jan. 21, 2005, pp. 16.

Japan Patent Office computer translation of publication No. JP2002320577, printed Jan. 24, 2005, pp. 18.

Japan Patent Office computer translation of publication No. JP07322980, printed Jan. 24, 2005, pp. 14.

Japan Patent Office English translation of abstract of publication No. JP53058160A, printed Feb. 17, 2005, pp. 1.

Japan Patent Office English translation of abstract of publication No. JP53128158A, printed Feb. 17, 2005, pp. 1.

Japan Patent Office computer translation of publication No. JP08-117165, Vacuum Cleaner and Its Operation Control, publication date May 14, 1996.

Japan Patent Office computer translation of publication No. JP10-094504, Vacuum Cleaner, publication date Apr. 14, 1998.

Japan Patent Office computer translation of publication No. JP2003-235767, Vacuum Cleaner, publication date Aug. 26, 2003.

Japan Patent Office computer translation of publication No. JP08-065876, Overcurrent Protection Device, publication date Mar. 8, 1994.

Patent Abstracts of Japan, JP08033596A2, Electric Vacuum Cleaner, publication date Feb. 6, 1996.

Ultimate Air Inc., The Ultimate Air RecoupAerator 200DX Energy Recovery Ventilator, Owner's Manual and Installation Guide, Jan. 24, 2006, pp. i-iv, 1-41 Athens, USA.

Heritage Central Vacuum, Crush Proof Hoses Non-Electric, <http://www.heritagevac.com/hosesnonelectric.html>, printed Sep. 21, 2005, pp. 4, Azusa, USA.

International Search Report for PCT/CA03/00382 dated Jul. 10, 2003.

The Eureka Company, Cordless, Rechargeable Vacuum Cleaner, Household Type, Owner's Guide, Model 570, 2000, pp. 12, Bloomington, USA.

The Eureka Company, Cordless, Rechargeable Vacuum Cleaner, Household Type, Owner's Guide, Model 96B, 2001, pp. 12, Bloomington, USA.

* cited by examiner

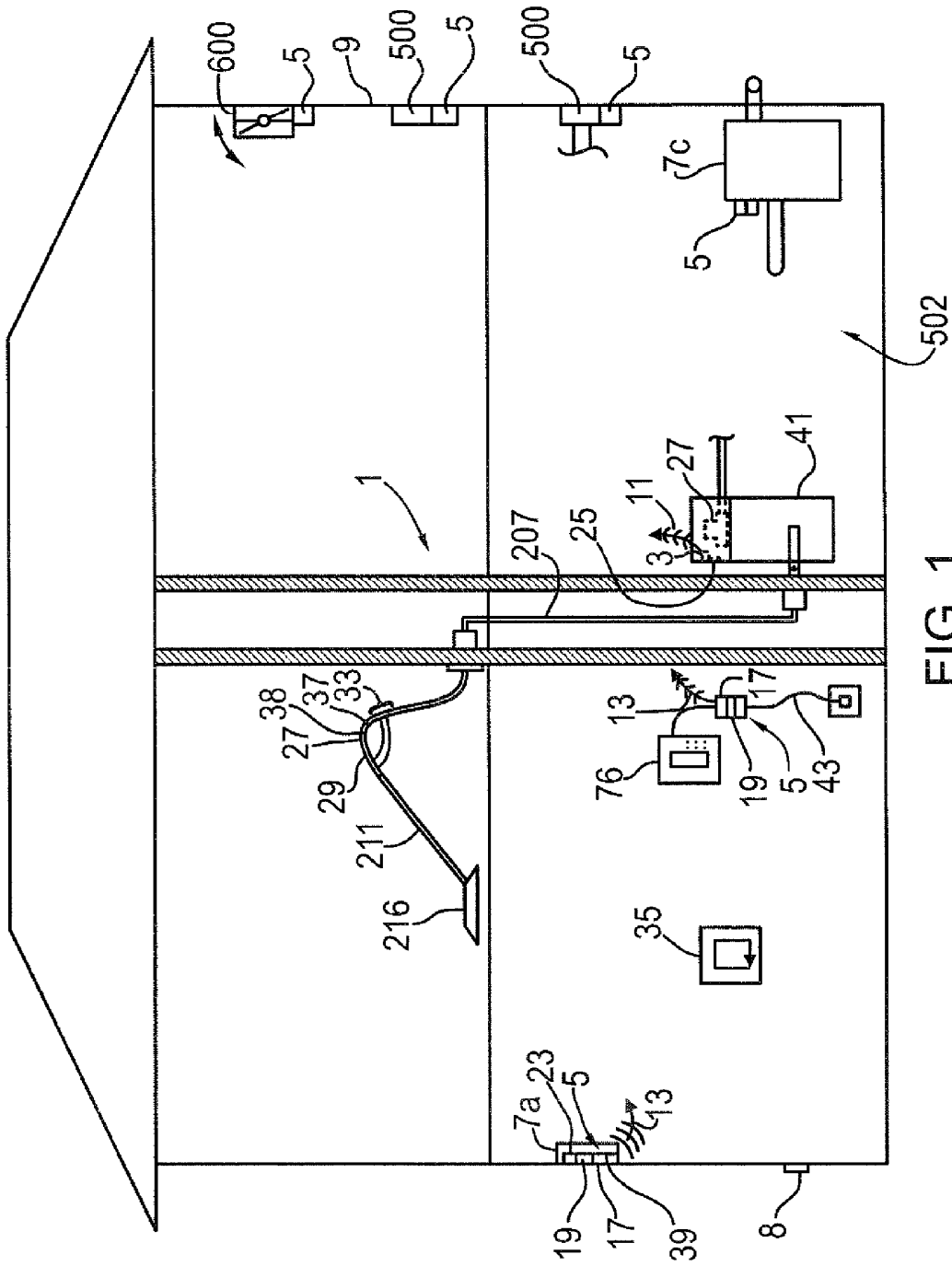

FIG. 1

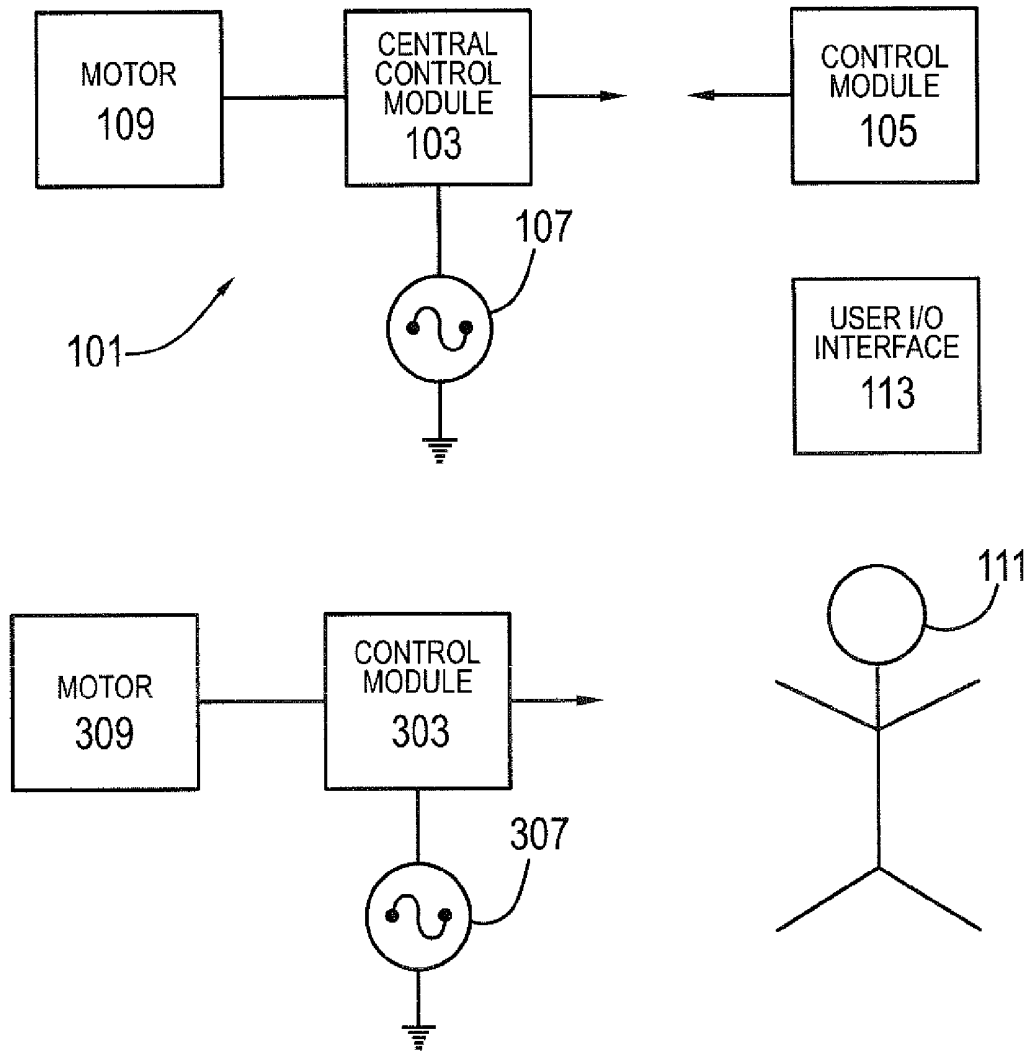

FIG. 2

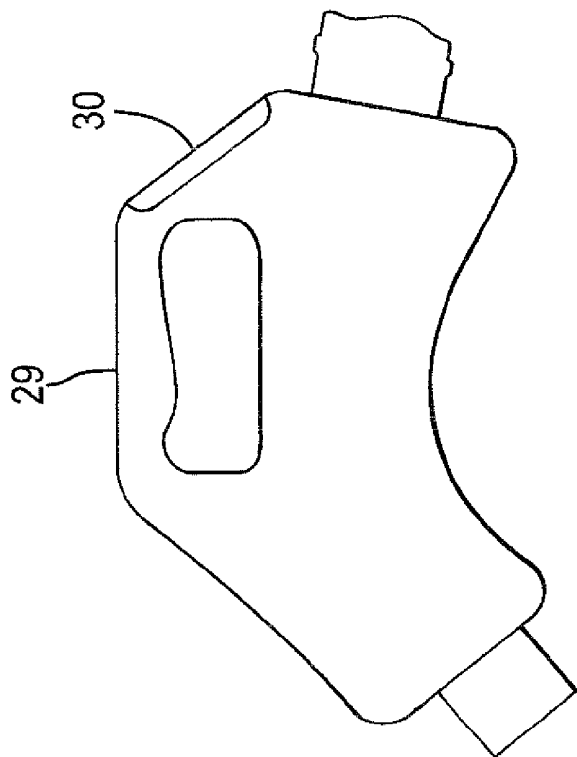

FIG. 4

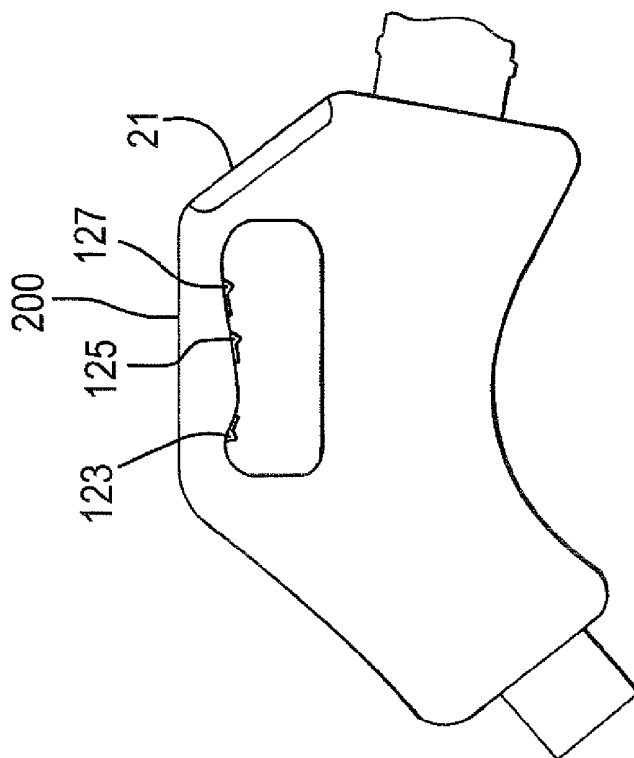

FIG. 3

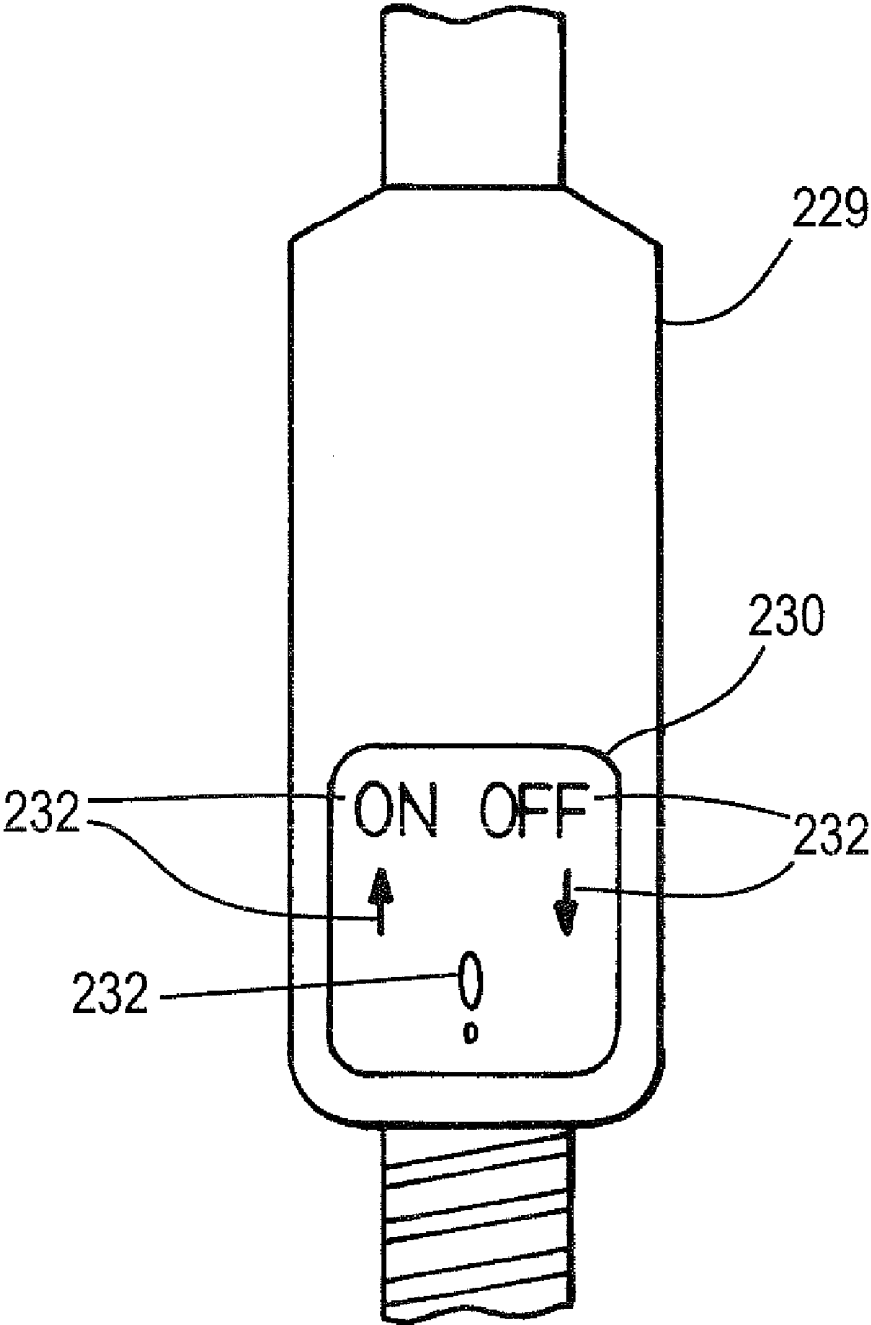

FIG. 5

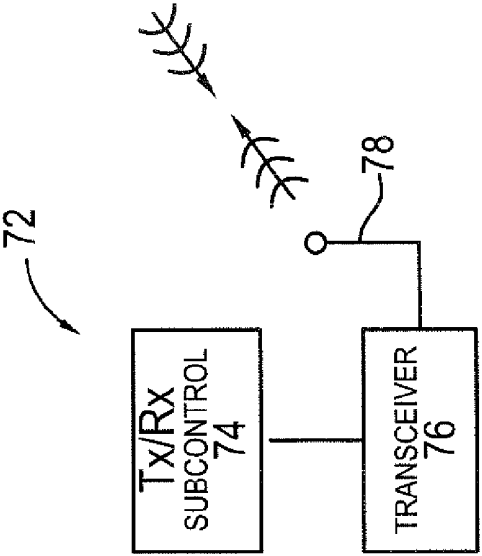

FIG. 8

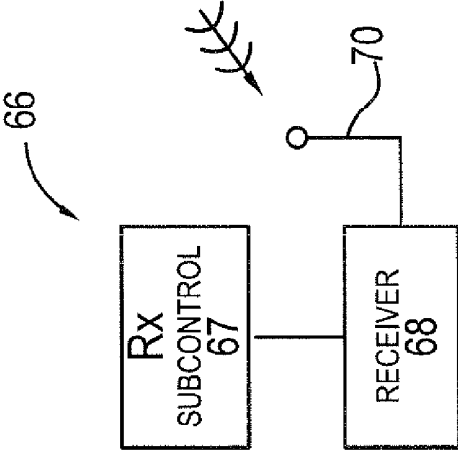

FIG. 7

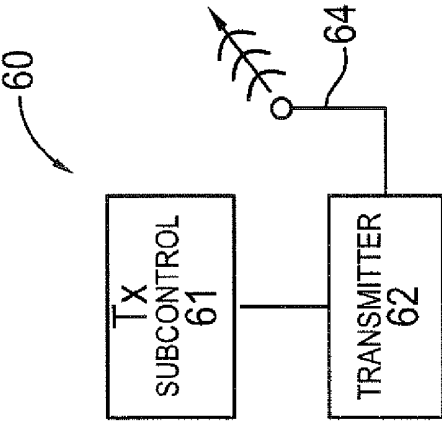

FIG. 6

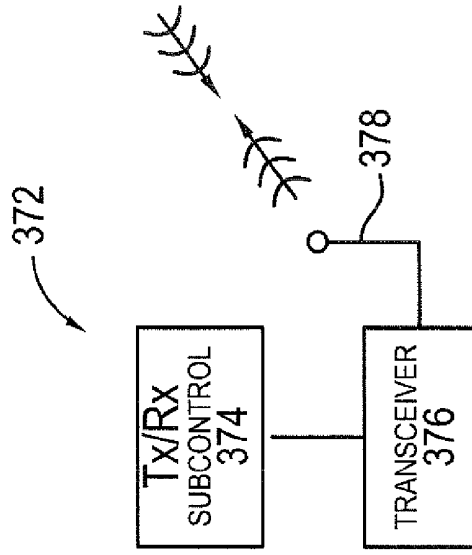

FIG. 8a

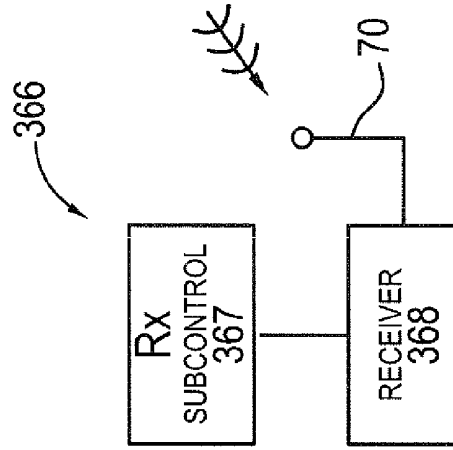

FIG. 7a

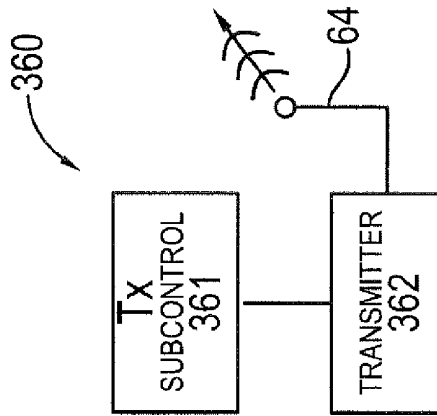

FIG. 6a

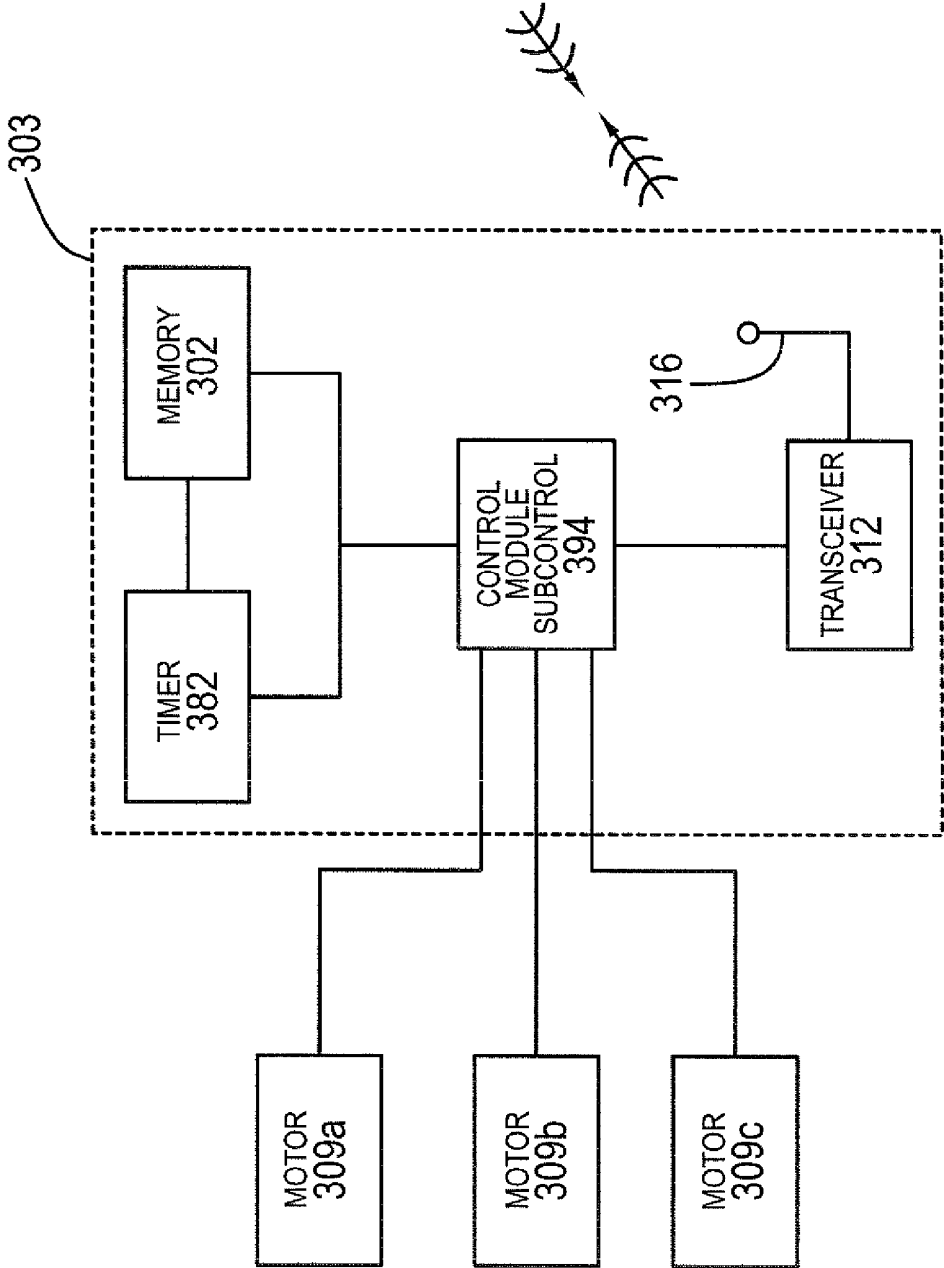

FIG. 9

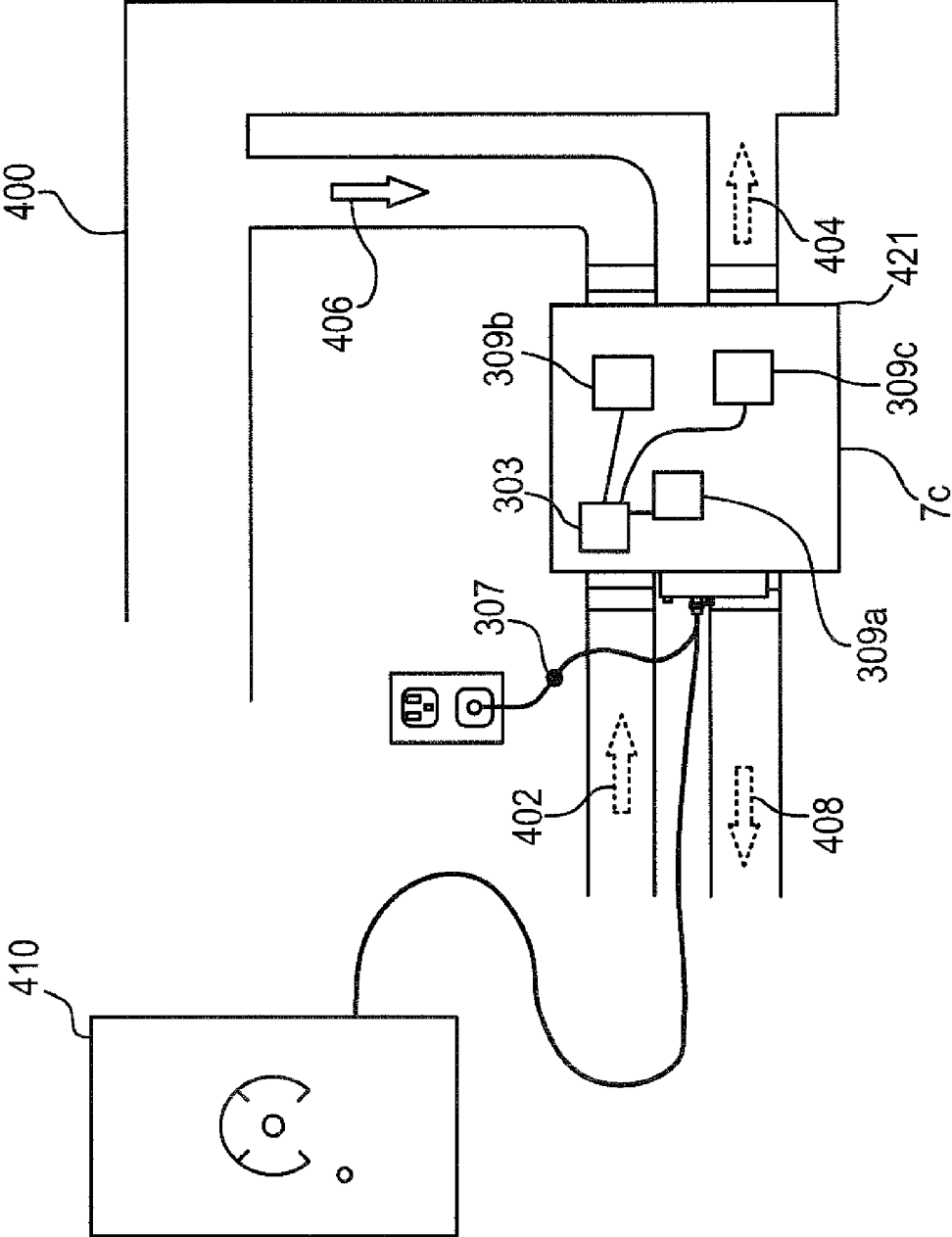

FIG. 10

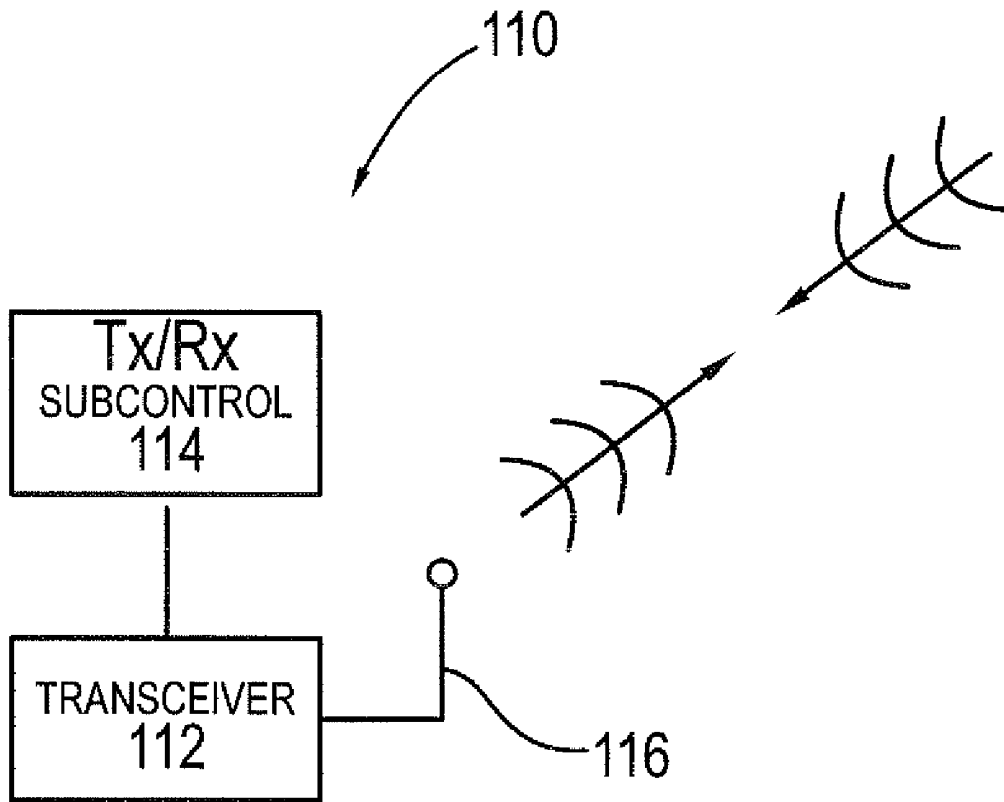

FIG. 11

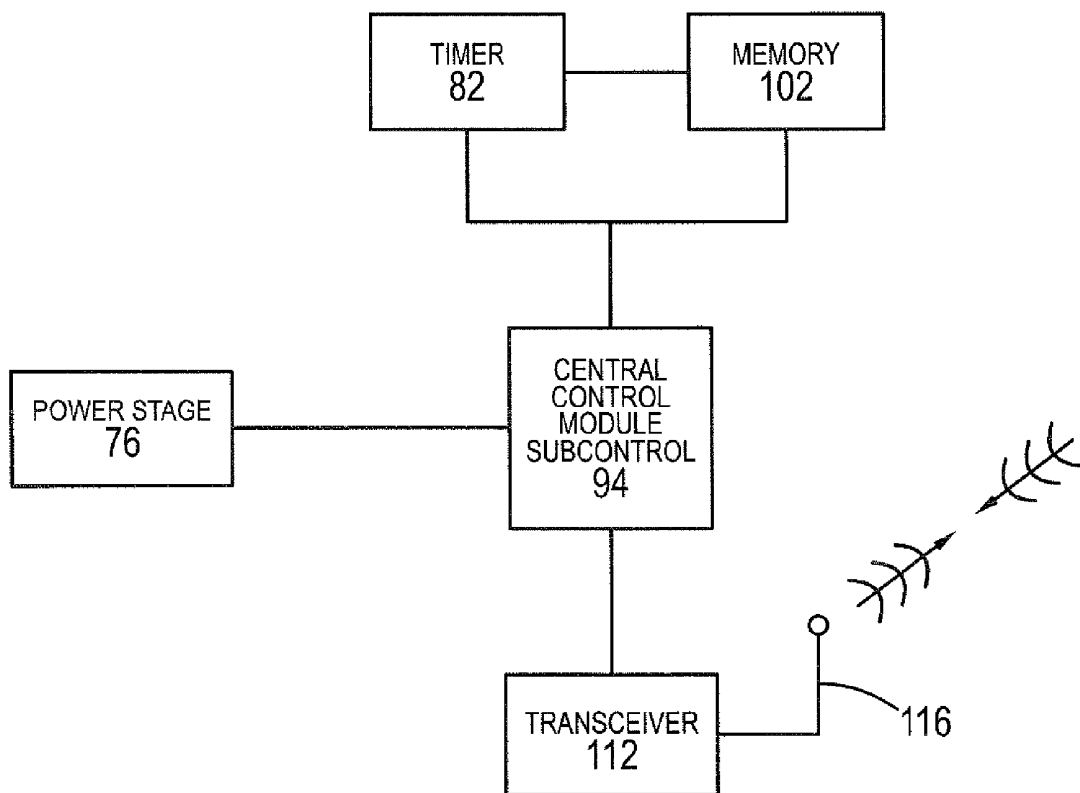

FIG. 12

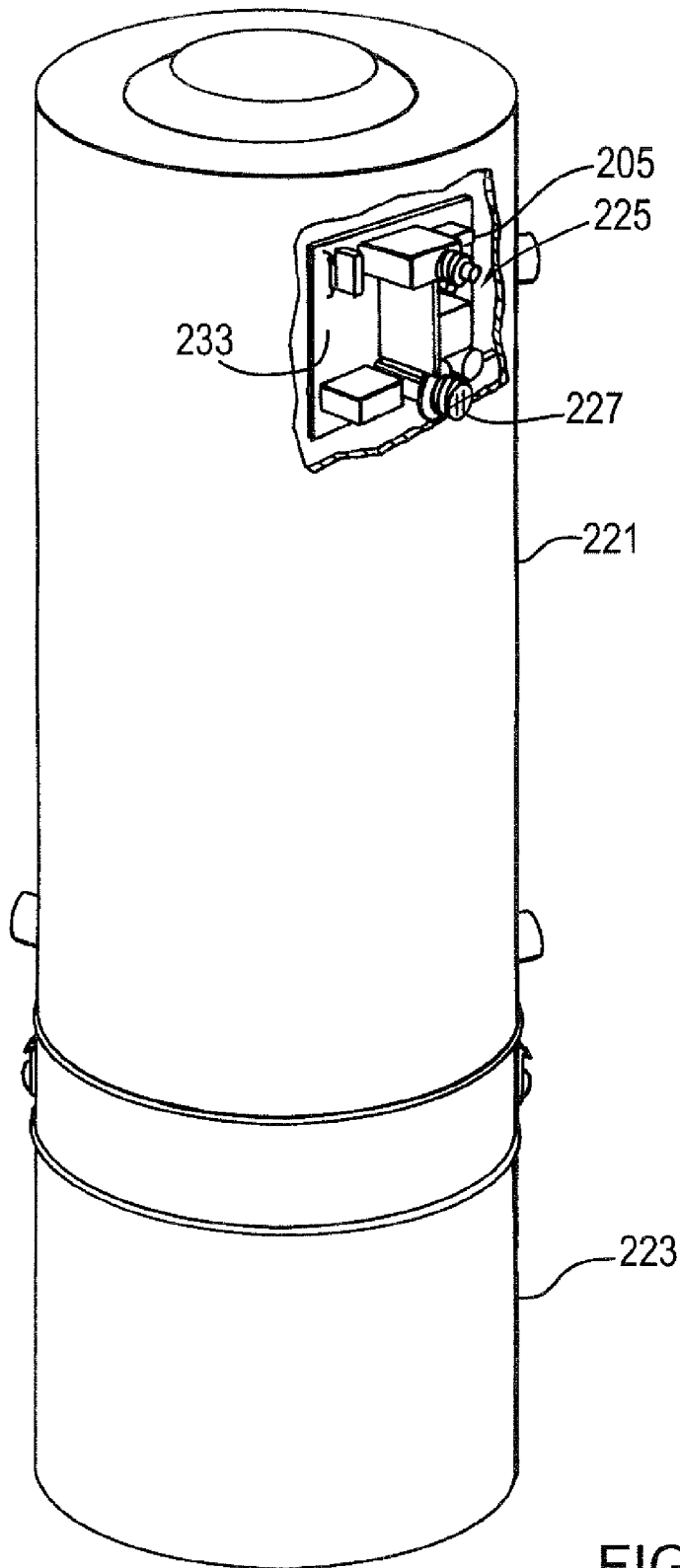

FIG. 13

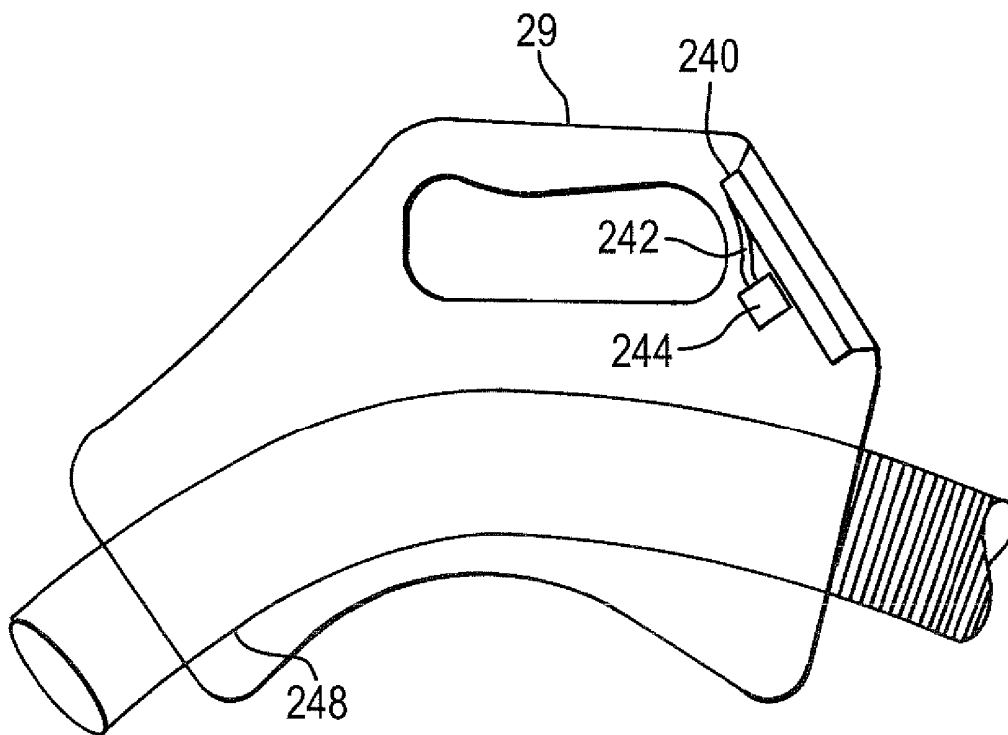

FIG. 14

CENTRAL VACUUM CLEANER CROSS-CONTROLS

This application claims priority from, and is entitled to the benefit of the filing date of, U.S. patent application No. 60/784,770 entitled CENTRAL VACUUM CLEANER CROSS-CONTROLS filed 23 Mar. 2006; U.S. patent application No. 60/724,290 entitled VACUUM CLEANER CROSS-CONTROL filed 7 Oct. 2005; and U.S. patent application No. 60/777,528 entitled CENTRAL VACUUM CLEANER CROSS-CONTROLS filed 1 Mar. 2006. The content of each of the above applications is hereby incorporated by reference into the detailed description hereof.

FIELD OF THE INVENTION

The invention relates to vacuum cleaners.

BACKGROUND OF THE INVENTION

Central vacuum cleaning systems were originally quite simple. One placed a powerful central vacuum source external to the main living space. The source was connected through interior walls to a long flexible hose that terminated in a handle and nozzle. When an operator desired to use the system, the operator went to the source and turned it on. The operator then went inside, picked up the handle and directed the nozzle to an area to be cleaned.

Although many elements of the basic system remain, many improvements have been made. Rigid pipes typically run inside interior walls to numerous wall valves spaced throughout a building. This allows an operator to utilize a smaller hose while covering an equivalent space. This is an advantage as the hose can be quite bulky and heavy.

Various communication systems have been developed. Some systems sense sound or pressure in the pipes to turn the vacuum source on or off, see for example U.S. Pat. No. 5,924,164 issued 20 Jul. 1999 to Edward W. Lindsay under title ACOUSTIC COMMUNICATOR FOR CENTRAL VACUUM CLEANERS. Other systems run low voltage wires between the source and the wall valve. The source can be turned on and off at a wall valve by a switch that may be activated by insertion or removal of the hose. The hose may also contain low voltage wires to allow the source to be controlled from a switch in the handle, see for example U.S. Pat. No. 5,343,590 issued 6 Sep. 1994 to Kurtis R. Radabaugh under title LOW VOLTAGE CENTRAL VACUUM CONTROL HANDLE WITH AN AIR FLOW SENSOR. The switch can be a simple toggle switch, or a more sophisticated capacitive switch.

The low voltage wires running along the pipes can be replaced by conductive tape or the like on the pipes, see for example U.S. Pat. No. 4,854,887 issued 8 Aug. 1989 to Jean-Claude Blandin under title PIPE SYSTEM FOR CENTRAL SUCTION CLEANING INSTALLATION. Separate low voltage conductors in the walls can be avoided altogether by home using mains power wires to transmit communication signals between the wall valve and the source, see for example U.S. Pat. No. 5,274,878 issued 4 Jan. 1994 to Kurtis R. Radabaugh, et al. under title REMOTE CONTROL SYSTEM FOR CENTRAL VACUUM SYSTEMS. A handheld radio frequency wireless transmitter can be used by an operator to turn the source on or off, see for example U.S. Pat. No. 3,626,545 issued 14 Dec. 1971 to Perry W. Sparrow under title CENTRAL VACUUM CLEANER WITH REMOTE CONTROL.

Line voltage can be brought adjacent the vacuum wall valves and connected to the handle through separate conductors, or integrated spiral wound conductors on the hose. Line voltage can then be brought from the handle to powered accessories, such as an electrically-powered beater bar, connected to the nozzle. Line voltage can be switched on and off to the powered accessory using the same switch in the handle that controls the source. Alternatively, the powered accessory may have its own power switch.

A control module mounted to the central vacuum unit is typically used to control the vacuum source. As central vacuum cleaning systems have become more and more sophisticated, so has the control module.

Improvements to, or additional or alternative features for, central vacuum cleaning systems are desirable.

SUMMARY OF THE INVENTION

In a first aspect, the invention provides a vacuum cleaning system for use in a structure. The system includes a receiver adapted to receive communications that an appliance has been activated, and a control circuit adapted to control the central vacuum cleaning system upon receipt of a communication at the receiver that the appliance has been activated.

The appliance may be a telephone and the telephone may be activated when there is an incoming call on the telephone.

The control circuit may be adapted to activate an alert in the vacuum cleaning system to alert a user to an incoming telephone call.

The alert may be a visual or tactile alert.

The control circuit may be adapted to turn off the cleaning system when there is an incoming telephone call.

The appliance may be a doorbell.

The control circuit may be adapted to activate an alert in the vacuum cleaning system to alert a user to activation of the doorbell.

The control circuit may be adapted to turn off the cleaning system when the doorbell is activated.

The adapter may be adapted to sense activation of the appliance and transmit a communication to the receiver.

The adapter may be a telephone line adaptor that may be adapted to sense incoming calls on the telephone line.

The adapter may be a doorbell adapter that may be adapted to sense activation of the doorbell.

The receiver may be a wireless radio frequency receiver and the communications may be wireless radio frequency communicators.

In a second aspect, the invention provides combination for use in a structure. The combination includes a vacuum cleaning system in the structure, an appliance in the structure, a system communications module associated with the system, and an appliance communications module associated with the appliance. The system communications module and appliance communications module is adapted to transmit communications to one another and to receive communications from one another. Such communications communicate a condition of the system or appliance with which the transmitting module is associated to the receiving module. The appliance or system with which the receiving module is associated is adapted to be controlled in accordance with the received communications.

In another aspect the invention provides a combination for use in association with a structure. The combination includes a vacuum cleaning system in the structure, an air intake device, a system communications module associated with the system, and an air intake device communications module associated with the air intake device. The system commu-

3

nications module is adapted to transmit communications and the air intake device communications module is adapted to receive communications from the system communications module. The air intake device is adapted to provide make-up supply air to the structure in proportion to running time of the vacuum cleaning system.

The air intake device may be an energy recovery ventilator (ERV) in the structure. The ERV may be a heat recovery ventilator (HRV). The system communications module may be adapted to transmit wirelessly, and the air intake device communications module may be adapted to receive the transmissions wirelessly.

The vacuum cleaning system may be a central vacuum cleaning system including a central control module adapted to controlling a vacuum source of the system and including a remote control module adapted to wirelessly transmitting communications to the central control module. The air intake device communications module may be adapted to receive transmissions wirelessly from the remote control module.

The air intake device may be a blower. The air intake device may be adapted to utilize pressure differential to draw in make-up air to the structure. The air intake device may be a damper.

In a fourth aspect the invention provides a method of controlling a central vacuum cleaning system. The method includes receiving communications at the central vacuum cleaning system when an appliance has been activated, and controlling the central vacuum cleaning system upon receipt of the communications.

Other aspects of the invention, including control modules and components thereof and methods of operation, will be evident from the principles contained in the description and drawings herein.

BRIEF DESCRIPTION OF THE DRAWINGS

For a better understanding of the present invention and to show more were clearly how it may be carried into effect, reference will now be made, by way of example, to the accompanying drawings that show the preferred embodiment of the present invention and in which:

FIG. 1 is a cross-section of a structure incorporating a central vacuum cleaning system control subsystem and ERV control subsystem in accordance with a preferred embodiment of the present invention;

FIG. 2 is a schematic diagram of a central vacuum cleaning system control subsystem and ERV control subsystem in accordance with the preferred embodiment of the present invention;

FIG. 3 is a side view of a central vacuum cleaning system hose handle for use with the subsystem of FIG. 2;

FIG. 4 is a side view of an alternate central vacuum cleaning system hose handle for use with the subsystem of FIG. 2;

FIG. 5 is a plan view of the handle of FIG. 4;

FIG. 6 is a block diagram of a central transmitter submodule for use in the central vacuum cleaning system control subsystem of FIG. 2;

FIG. 7 is a block diagram of a central receive submodule for use in the central vacuum cleaning system control subsystem of FIG. 2;

FIG. 8 is a block diagram of a central transceiver submodule for use in the central vacuum cleaning system control subsystem of FIG. 2;

FIG. 6a is a block diagram of a central transmitter submodule for use in the ERV system control subsystem of FIG. 2;

FIG. 7a is a block diagram of a central receive submodule for use in the ERV system control subsystem of FIG. 2;

4

FIG. 8a is a block diagram of a central transceiver submodule for use in the ERV system control subsystem of FIG. 2;

FIG. 9 is a block diagram of an ERV control module for use in the ERV control subsystem of FIG. 2;

FIG. 10 is a schematic diagram of a preferred embodiment of an installed ERV in accordance with a preferred embodiment of the present inventions and incorporating the ERV control module of FIG. 9;

FIG. 11 is a block diagram of a remote transceiver submodule for use in the central vacuum cleaning system subsystem of FIG. 2;

FIG. 12 is a detailed block diagram of an ERV submodule for use in the ERV system subsystem of FIG. 2;

FIG. 13 is a cut-away perspective view of a vacuum source for use in the cleaning system of FIG. 1; and

FIG. 14 is a cross-section of a hose handle incorporating a remote control module in accordance with a preferred embodiment of the present invention.

DETAILED DESCRIPTION OF THE PREFERRED EMBODIMENT

Referring to FIG. 1, a vacuum cleaning system 1 has a communication module 3 that communicates with corresponding appliance communication module(s) 5 for appliance(s) 7. The system communication module 3 may transmit communications 11 to the appliance communication module 5. Alternatively, the module 5 may transmit communications 13 to the module 3. The modules 3, 5 may both receive and transmit. Preferably, the communications 11, 13 are radio frequency (RF) wireless as shown; however, wired communications, where wiring is possible or available, are also suitable. To the extent that the modules 3, 5 are to transmit communications, each incorporates a transmitter 17, not shown in module 3. To the extent that the modules 3, 5 are to receive communications, each incorporates a receiver 19, not shown in module 3.

As is clear from the detailed description hereof, an appliance 7 is a device separate from the central vacuum system 1. The appliance 7 performs a task unassociated with the function of the central vacuum cleaning system 1.

As an example, the appliance 7 may be an electrically-activated doorbell 7a. The doorbell 7a is electrically activated when a user presses a switch 8 adjacent to a door. The communications module 5 incorporates a sensor 23 that recognizes electrical activation of the doorbell. The communication module 5 transmits through transmitter 17 a communication 13 to the module 3. The receiver in the module 3 receives the communications 13.

The system 1 has a system control circuit 25 that controls the cleaning system 1 in accordance with the communication 13 received by the communication module 3. For example, if the cleaning system 1 is on and the control circuit 25 determines that vacuum source 27 is operating, then there may be significant noise in the structure 9. The control circuit 25 may assist the user by alerting the user to the activation of the doorbell.

The alert may be in the form of a visual alert, such as an LED 27 flashing on a hose handle 29, an icon alert flashing or displayed on an LCD screen 33 on the hose handle 29, or similar visual alerts on a remote display for system 1, such as a wall display 35.

The alert may be in the form of a tactile alert, such as a vibration mechanism 37 in the hose handle 29. The control circuit 25 may turn off power to the vacuum source 27 upon activation of the doorbell.

For central vacuum cleaners, the alert may be in the form of an audible alert, such as a buzzer, horn or other sound generator **38** in the hose handle **29**. An audible alert may also be used in a portable vacuum cleaner; however, its effectiveness may be limited by noise from vacuum source.

As a further example, the module **3** may transmit a communication **11** through transmitter **15** to the doorbell appliance module **5** receiver **19**. The doorbell appliance module **5** has a control circuit **39** to activate the doorbell. The doorbell can be activated in a given pattern to indicate that it is not a regular doorbell activation, but rather that the system **1** requires attention. The control circuit **25** may provide additional information through the alerts previously described, or other locations such as at vacuum unit **41**.

As a further example, the appliance **7** may be a telephone **7b**. The module **5** may be a telephone line adapter that senses an incoming call on the line **43**. Similar to the functions of the module **5** when used with the doorbell, it communicates to the module **3**, which behaves in a similar manner, including perhaps illuminating a telephone icon.

The module **5** as telephone line adapter can also be used to activate a ring at the telephone. The ring may be in a distinctive pattern, or the module may cause a message to be played indicative of the alert, or simply indicating that the system **1** should be checked for further information.

As a further example, central vacuum systems are typically exhausted outside the dwelling and this can cause negative pressure in an airtight structure.

The appliance **7** may be a heat recovery unit or heat recovery ventilator (HRV) or energy recovery unit, more currently and generically referred to as an energy recovery ventilator (ERV), **7c**. Those ERVs that exchange relatively warm air from a structure with cooler outside air to maintain the heating efficiency of a structure are often described using the terms heat recovery units or heat recovery ventilators (HRVs). Those ERVs that exchange relatively cool air from a structure with warmer outside air to maintain the cooling efficiency of a structure are typically referred to as energy recovery units or energy recovery ventilators (ERVs). It is to be understood that both heating and cooling air exchangers fall under the generic term ERVs and operate under the same principles. ERVs can be configured to operate as both heating and cooling air exchangers at different times. Often ERVs are optimized for heating or cooling efficiency and marketed under different names; however, they fall under the broad category of ERVs.

In today's virtually airtight structures, an ERV **7c** is used to bring in air from outside the structure **9** while recovering energy from the exhausted air. When control circuit **25** senses operation of the vacuum source **41**, the module **3** can be directed to communicate this via communication **11**.

Module **5** at the ERV **7c** receives the communication **11** through receiver **17**. The module **5** activates the ERV **7c** to let in more air to the structure **9**.

Any of the modules **5** discussed herein may be separate from their related appliance or integrated with it.

As an example, the system **1** may send a communication **11** to an appliance **7** when it requires servicing, such as bag full, motor bearing, or motor brush servicing. As another example, the system **1** may also send a communication **11** to an appliance **7** when it senses an environmental condition worthy of alerting a user, see for example, co-pending United States utility patent application of Allen D. Muirhead and J. Vern Cunningham filed 7 Oct. 2005 under title CENTRAL VACUUM CLEANER CONTROL, UNIT AND SYSTEM WITH CONTAMINANT SENSOR and application Ser. No.

11/245,218 the content of which is hereby incorporated by reference into this detailed description.

Referring to FIG. 2, detailed examples of central vacuum system/ERV combinations with cross-control will be described herein. A central vacuum cleaning system control subsystem **100** has a vacuum central control module **103** and a remote control module **105**. An ERV control subsystem **300** has an ERV control module **303**.

The central control module **103** controls power from a power source **107** to a motor **109**, and by doing so the central control module **103** controls the operation of the motor **109**. The power source **107** is typically line voltage, for example, 120V or 240V, 60 Hz AC in North America or 230V, 50 Hz AC in Europe.

The remote control module **105** is connected to a user input/output interface **113**. The remote control module **105** receives input from a user **111** through the interface **113**. User input may be as simple as a request for a change of state of the motor **109** where the interface **113** would be a toggle switch **113**.

The ERV control module **303** controls power from a power source **307** to motors **309**, and by doing so the ERV control module **303** controls the operation of the motors **309**. The power source **307** is typically line voltage, for example, 120V or 240V, 60 Hz AC in North America or 230V, 50 Hz AC in Europe.

The remote control module **105** is a wireless transmitter. It encodes the input received from the user for wireless transmission to the central control module **103** as indicated by the arcs **115**. It also provides wireless transmissions to the ERV control module **303** as indicated by the arcs **115**.

The central control module **103** is a wireless receiver. It receives the wireless transmission from the remote control module **105**, decodes it and controls the motor **109** accordingly. For example, if the user requests the motor **109** to change state then if the central control module **103** is providing power from the source **107** to the motor **109** then the central control module **103** will cease doing so. If the central control module **103** is not providing power from the source **107** to the motor **109** then it will provide power.

The ERV control module **303** is a wireless receiver. It receives wireless transmissions from the remote control module **105**, decodes them and controls the motors **309** accordingly.

The central control module **103** is also a wireless transmitter. The central control module **103** senses the operating condition of the motor **109**, encodes a message related to the condition and wirelessly transmits the message to the remote control module **105** as indicated by the arcs **117**. The message is received by the remote control module **5**, decoded, and provided to the user through the interface **113**.

The ERV control module **303** is also a wireless transmitter. The ERV control module **303** senses the operating condition of the motors **309**, encodes a message related to the condition and wirelessly transmits the message to the remote control module **105** as indicated by the arcs **317**. Such a message received by the remote control module **105**, is decoded, and provided to the user through the interface **113**.

Referring to FIG. 3, a hose handle **200** incorporates the interface **113** as a display means **121** and switch **123**. A toggle switch **123** is shown in the FIGS.; however, various types of switches, such as for example a momentary switch, not shown, could be used. The display means **121** may take the form of one or more lights, such as LEDs and/or an LCD screen with icons. Alternatively, or in addition, the display means may have a speaker or buzzer to provide sound output to the user by way of voice or an alarm. A transducer may be

used to create sounds. This provides bi-directional communication between the central control module 103 and the remote control module 105, and between the remote control module 105 and the ERV control module 303, and thereby provides bidirectional communication between the user 111 and the motor 109, and the user 111 and the motors 309, as will be discussed further herein.

In a preferred embodiment, the central control module 103 is able to provide more complex control of the motor 109 beyond simply turning it on and off. For example, the central control module 103 may be able to adjust the speed at which the motor 109 operates. There are many different techniques for adjusting motor 109 speed, some of which are dependent on the type of motor 109.

For example, existing central vacuum cleaning systems typically use a universal motor 109. The speed of a universal motor 109 can be controlled by reducing the voltage applied to the motor 109. DC motors 109 have also been described for use as vacuum motors 109, see for example, co-pending PCT Patent Application No. PCT/CA03/00382 filed 12 Mar. 2003, published 18 Sep. 2003 as WO03075733A1, and claiming the benefit of U.S. Provisional Patent Application No. 60/363,351 filed 12 Mar. 2002. The content of the above applications is hereby incorporated by reference into the Detailed Description hereof. The speed of a DC motor 109 can be adjusted by adjusting the voltage for a series wound motor 109, or by controlling the excitation on the armature of a shunt wound motor 109.

Where the central control module 103 has the ability to control motor 109 speed then it may be desirable to provide for a "soft start". This can be done by starting the motor 109 at a slower desired speed and working up to a higher speed. This can increase the longevity of the motor 109, particularly for universal motors 109 where starting can result in a high inrush current that has a cumulative detrimental effect on motor 109 windings over time. Soft start control can be configured as an internal setting of the central control module 103 without requiring external user input.

The user 111 can be permitted to adjust the speed of the motor 109 on demand by requesting such an adjustment through the user input/output interface 113. This can be done by providing additional user inputs at the interface 113, for example more switches 125, 127, or it may be more effectively done by interpreting the signals from the user 111 through a lesser number of inputs, for example switch 123 only. For example, the switch 123 can be actuated to signal a particular request. A series of switch 123 actuations may signal a request for a decrease motor 109 speed another series of switch 123 actuations may signal a request for an increase in motor 109 speed. Another signal would indicate on and another off.

An easier interface 113 for the user 111 would include two switches 123, 125. Repeated actuation of one switch 123 signals a request for an increase in speed, while repeated actuation of the other switch 125 signals a request for a decrease in speed. A single actuation of one switch 123 could indicate a request to turn the motor 109 on, while a single actuation of the other switch 125 could indicate a request to turn the motor 109 off. For example, each request for a decrease in speed could result in a 10% reduction to a maximum of a 50% reduction. Rather than incrementally increasing speed, the user could be required to request the motor 109 to be turned off and then on through the interface 113. This could reset the speed to 100%.

More switches or input devices, not shown, could be added as desired. For example, the user can also be permitted through the user interface 113 manually to control the motors

309, by activating the motors 309 or changing the speed of the motors 309. Preferably user input to the interface 113 to turn on and off the motor 109 is used by the remote control module 105 to communicate with the ERV control module 303 in order to provide automated control of the motors 309. The motors 309 could be controlled based simply on a user 111 requesting the motor 109 to be turned on and subsequently based on a user 111 requesting the motor 109 to be turned off. For example, the ERV 7c could be controlled to turn on when the user 111 requests the motor 109 to be turned on, and the ERV 7c could be controlled to turn off when the user 111 requests the motor 109 to be turned off.

When the ERV 7c is turned on it could be controlled to draw in supply air only to make up for air that is exhausted by the central vacuum system. Alternatively, the ERV could be controlled to draw in supply air and take out exhaust air, while providing an offset to draw in more supply air than the ERV exhausts.

Preferably, the amount of time that the motor 109 is turned on is tracked and the motors 309 are controlled after a delay time period to draw in make-up supply air that is proportional to the air exhausted by the central vacuum cleaning system. The delay period is set to allow running time of motor 109 to accumulate before controlling the motors 309. The delay period is beneficial as motor 109 may be switched on and off during vacuuming. The delay period allows the motors 309 to be controlled less often for each vacuuming session, preferably once. This can reduce wear on the motors 309. Although a modern ERV 7c is quite quiet, the delay period can also reduce annoyance from changes in background noise in the structure from numerous changes in state of the ERV 7c.

The delay period could, for example, be 15 minutes. The delay period should reflect an amount of time during which a user 111 would ordinarily take during vacuuming to run the motors 109 for an accumulated period of time that justifies running of the ERV 7c. It can also reflect an amount of time that it would ordinarily take for a person to complete a vacuuming task.

A minimum running threshold can be used such that the ERV 7c does not draw in make-up supply air until more than a given period of accumulated running time has elapsed. This avoids turning on the ERV 7c for minor or inadvertent uses of the vacuum cleaning system. If the minimum running threshold is not reached during a given period of time (which may match the delay time or be longer) then the accumulated running time is reset to zero.

A delay override threshold can be used such that the ERV 7c begins drawing make-up supply air after a given period of accumulated running time for the motor 109 has elapsed. This avoids reductions of pressure during constant vacuuming.

The delay period and thresholds will ordinarily be factory set for general usage. They can be set based on specific vacuum cleaning systems and ERVs, ranges of such systems and ERVs, or generally, for example for all such residential systems.

The delay period and thresholds could be provided with default settings combined with in situ learning. For example, vacuuming session times could be tracked for multiple vacuuming sessions. The delay period could be reduced or lengthened based on actual accumulation vacuuming session statistics. For example, in a small structure where vacuum session times are typically short then the delay could be shortened. This would provide air balancing sooner. As a further example, the delay override threshold could be reduced in smaller structures. Similarly, if vacuuming session times are

shorter than it might be assumed that the structure is smaller and so is the ERV. This may allow for shorter minimum running threshold times.

Referring to FIGS. 4 and 5, an alternative interface 113 might be a touch screen 130 that could incorporate both a display and input device. The touch screen 130 could display various icons or text representing messages from the central control module 103 regarding the operating condition of the motor 109 and the motors 309. Icons or text could also be provided to allow the user 111 to send messages to the central control module 103 or the ERV control module 303 by touching the icons or text.

The central control module 103 also has a number of sub-modules. Referring to FIG. 6, central transmit submodule 60 has a transmit (Tx) subcontrol 61, a wireless transmitter 62 and an antenna 64. The Tx subcontrol 61 encodes messages to be transmitted wirelessly by transmitter 62 through the antenna 64.

Referring to FIG. 7, a central receive submodule 66 has a receiver (Rx) subcontrol 67, wireless receiver 68 and an antenna 70. The Rx subcontrol 67 decodes messages received by the receiver 68 through the antenna 70. The antenna 64 and 70 may be one in the same component if desired, and designed for, by the designer in a manner that would be evident to those skilled in the art.

Referring to FIG. 8, the central transmit submodule 60 and central receive submodule 66 may be replaced by a central transceiver submodule 72 having a transmit/receive (Tx/Rx) subcontrol 74, a transceiver 76 and an antenna 78. The submodule 72 encodes and decodes, transmits and receives messages through antenna 78 in a manner similar to the central transmit submodule 60 and the central receive submodule 66, combined.

The wireless transceiver 76 combines a transmitter and receiver in a single component. Among other benefits, the use of an integrated transceiver 76 can reduce complexity, power consumption and size. Also, transceiver for unlicensed short distance communication typically utilize higher frequencies for less interference and more effective communication.

This description will be made primarily with reference to a central transceiver submodule, such as submodule 72. It is to be understood that discrete transmit submodules, such as submodule 60, and discrete receive submodules, such as submodule 66, could be used as necessary for a particular application, if desired.

The ERV control module 303 also has a number of sub-modules that operate based on a variety of sensed conditions. Referring to FIG. 6a, ERV transmit submodule 360 has a transmit (Tx) subcontrol 361, a wireless transmitter 362 and an antenna 364. The Tx subcontrol 361 encodes messages to be transmitted wirelessly by transmitter 362 through the antenna 364.

Referring to FIG. 7a, ERV receive submodule 366 has a receiver (Rx) subcontrol 367, wireless receiver 368 and an antenna 370. The Rx subcontrol 367 decodes messages received by the receiver 368 through the antenna 370. The antenna 364 and 370 may be one and the same component if desired, and designed for, by the designer in a manner that would be evident to those skilled in the art.

Referring to FIG. 8a, the ERV transmit submodule 360 and ERV receive submodule 366 may be replaced by an ERV transceiver submodule 372 having a transmit/receive (Tx/Rx) subcontrol 374, a transceiver 376 and an antenna 378. The submodule 372 encodes and decodes, transmits and receives messages through antenna 378 in a manner similar to the ERV transmit submodule 360 and the ERV receive submodule 366, combined.

The wireless transceiver 376 combines a transmitter and receiver in a single component. Among other benefits, the use of an integrated transceiver 376 can reduce complexity, power consumption and size. Also, transceivers for unlicensed short distance communication typically utilize higher frequencies for less interference and more effective communication.

This description will be made primarily with reference to an EVR transceiver submodule, such as submodule 372. It is to be understood that discrete transmit submodules, such as submodule 360, and discrete receive submodules, such as submodule 366, could be used as necessary for a particular application, if desired.

Referring to FIG. 9, the ERV control module 303 has a timer submodule 380 with a timer 382, and a timer subcontrol 384. The timer 382 commences timing on the instruction of the subcontrol 384 when the user 111 requests activation of the motor 109 as received from the remote module 105. The timer 382 times until the ERV module 303 receives a request from the user 111 to stop the motor 109. Once a delay period has passed from the commencement of the original time then the timer 382 will activate the ERV 7c to draw in make-up supply air for a period proportional to that timed by the timer 382. If a request to turn on the motor 109 is received within the delay period, for example 15 minutes, then the timer will accumulate additional time for activation of the ERV 7c. This provides time-shifted pressure balancing.

In general, the amount of air removed by the central vacuum cleaning system is matched by make-up supply air from the ERV 7c to provide pressure balancing for the structure. For a simple embodiment, an assumption may be made that a vacuum cleaning system will exhaust approximately half the air as the ERV 7c supplies; so that, the ERV 7c can be run for approximately 30 secs for each minute that the vacuum cleaning system was running. If desired, an additional percentage of time can be added to make up for other exhaust loads in the structure, such as exhausts fans that are not directly connected to the ERV. Central vacuum systems exhaust air at one rate, while an ERV 7c will supply air at a different rate. Empirical tests can be performed generally for cleaning systems and ERVs 7c to determine what proportion is generally desirable.

Most residential central vacuum cleaning systems will exhaust air at a similar rate limited by the size of the motor 109 and the system piping. Thus, the more significant variable may be the ERV 7c specifications. Thus, it may be beneficial for the manufacturer (who is aware of its ERV specifications) to provide the timing settings for the timer 382.

For sophisticated control it may be desirable to measure the air flow of the ERV make-up supply in situ and match that for the desired timing. Various air flow measurement devices are known in the art.

In order to provide specifications on which timer delay and thresholds can be based, or the timer delay and thresholds, the ERV control module 303 can store these in non-volatile memory 302.

The timer settings could also be input directly by the user 111 at the interface 113 and transmitted from the remote control module 105 for reception at the transceiver 372, decoding by the transceiver subcontrol 374 and storage in memory 302. The memory 302 can be a rewriteable device such as, for example, an EEPROM, EPROM or flash memory device. Alternatively, the settings can be pre-configured in memory 302 by an installer, or at the time of manufacture. If the settings are input at the time of manufacture or installation then a write once memory device, such as a PROM, could be used, if desired.

The module **303** can also include components to sense operating conditions of the motors **309** and provide messages to the user **111** through the user interface **113**.

Referring to FIG. **10**, an ERV **7c** is shown, as an example, installed in conjunction with forced air ductwork **400** of a structure. The ERV **7c** draws in supply (fresh) air to the structure at **402** and provides that air to the ductwork **400** at **404**. The ERV **7c** is also capable of removing exhaust air from the ductwork **400** at **406** and exhausting that air from the structure at **408**. The ERV control module **303** controls the exhaustion and supply of air by the ERV **7c**. A typical wired wall control **410** and power source **307** are also shown.

As will be evident to those skilled in the art, the ERV **7c** can be installed in alternative configuration, for example, with its own dedicated ductwork.

ERVs **7c** can be implemented in many ways. Examples include cross flow plate core, counter flow flat-plate core, heat pipe core, and rotary wheel core. Rotary wheel core implementations can be implemented in configurations to regulate humidity in addition to providing air balancing. It is understood that the principles described herein apply to all types of heat exchangers; although, some features may not be available in all cases, and implementation may require adaptation for different configurations.

Different motors **309** and, possibly, numbers of motors **309** may be used for different configurations of ERVs. For example, a three motor configuration may utilize one motor **309a** to drive a rotary wheel, while a second motor **309b** drives an exhaust air blower, and a third motor **309c** drives a supply air blower. Alternatively, a first motor **309a** may drive a blower to draw air through the ERV **7c**, while a second motor **309b** drives a damper controlling the amount of exhaust air, and a third motor **309c** drives a damper controlling the amount of supply air.

In order to provide make-up supply air the module **303** activates the motor **309a** and only the motor **309c** to supply air, or activates the motors **309b** and **309c** in such a way as to provide a greater amount of supply air to the structure than is exhausted. If the motors **309b** and **309c** are blower motors then the motor **309b** may be driven at a slower speed than the motor **309c**. If the motors **309b**, **309c** are damper motors then the motors will drive the dampers to relative positions that provide more supply air than exhaust air.

The motors **309** are controlled by an ERV module subcontrol **394** of the module **303**. The subcontrol **394** may contain power stages, not shown, as necessary for driving the motors **309**. The subcontrol **394** will act in accordance with signals received from the timer **382**. Preferably the subcontrol **394** incorporates a microprocessor acting under instructions stored in memory **303** to control the motors **309** directly, or through the power stages.

Referring to FIG. **11**, remote control module **105** incorporates a remote transceiver submodule **110** similar to that of the central transceiver submodule **72**, including a remote transceiver **112**, remote transceiver subcontrol **114**, and antenna **116**. The operation of the remote transceiver submodule **110** and central transceiver submodule **72** are similar and will not be repeated. It is to be noted that the functions of the remote transceiver submodule **110** could be replaced by a separate transmitter submodule and/or receiver submodule, not shown.

In the preferred embodiment, the transceiver submodules **72**, **110** of central control module **103** and remote control module **105**, respectively, are matched for transmission and reception of signals over a distance of approximately 150 ft. through typical residential obstacles and building materials. The design distance is a matter of choice, governed by appli-

cable legal requirements such as might apply to signal strength and frequency. A digitally modulated radio frequency (r.f.) carrier of 433.92 MHz is suitable as it meets current North American and European requirements for r.f. control systems.

Alternatively, r.f. transmissions can operate in spread-spectrum mode. This could include frequency hopping spread spectrum or direct-sequence spread spectrum (DSS). These techniques enable operation at higher r.f. power levels than single frequency operation by distributing the power over a number of different frequency channels. In this case, the carrier frequency could be in the 850-950 MHz or 2.4 GHz bands to comply with legal requirements in North America and Europe. In this case, design for a minimum distance of approximately 300 ft. between central control module **103** and remote control module **105** is preferred.

Other r.f. transmission techniques and frequencies could be used as desired for particular applications.

A microprocessor can be used as the transceiver subcontrol **114** in the remote control module **105** to provide the digital encoding of r.f. carrier with message data, and to decode messages received from the central control module **103**. Other devices such as a microcontroller or discrete components could be used to perform these functions.

Wireless communication provides a significant advantage. Wired low voltage signals require a step down transformer from line voltage to low voltage, such as a class H safety transformer. Wireless communication obviates the need for low voltage signals and the class II transformer for that purpose.

The central control module **103** can be powered using a drop down resistor or capacitor from the power source **109**. A non-class II transformer can be used in the event that larger power is required as wireless communication does not require the use of a class II transformer. It may still be desired to use a class II transformer in order to allow a manufacturer to provide an option to communicate via low voltage wires connected between the central control module **103** and the remote control module **105**. The selection between wired and wireless communication can be made at the time of manufacture, or the manufacturer can leave this selection up to the installer. If the selection is made by the manufacturer than separate different central control modules and remote control modules can be made for wired and wireless configurations.

It is to be understood that wireless communication is not required for all of the functions described herein. In fact, for many functions it is not necessary to have communication between the user **111** and the central vacuum source **205**, except to turn the motor **109** on and off. The other functions can operate without user intervention.

Referring to FIG. **12**, the various submodules of the central control module **103** can be combined. In combining the submodules, the various subcontrols can also be combined into a single central control subcontrol **94** which can utilize a single microprocessor, microcontroller or combination of discrete components, to perform the functions described herein for each of the submodules. The memory **102** can be part of the microprocessor or microcontroller, or it may itself be a discrete component. Preferably, the central control subcontrol is a microprocessor with integrated memory **102**. The entire timer submodule may be part of the microprocessor, or it may be a combination of the microprocessor and a few discrete components to set the proper timing for the timer. Alternatively, the timer may comprise components discrete from the microprocessor.

The various subcontrols, microprocessor and microcontroller are programmed to perform the functions described

herein. The programs are contained in a non-volatile memory, such as memory 102, or an internal memory within the sub-control, microprocessor or microcontroller.

Control signals, such as ON/OFF, from the operator 111 are provided through a switch 123 (or switches 123 or some other interface 113 in the handle 29. More sophisticated systems may utilize the control signals for many other purposes, such as duplex communications that allow the receipt of information at the handle 29. Such information could be used to drive LEDs or other display means (as described previously for the interface 113) for communication with the operator 111. When the operator 11 turns on the system 1, dirt is drawn by a vacuum created by the vacuum source 27 through attachment 216, handle 29, hose 211, and pipes 207.

Referring to FIG. 13, the vacuum source 205 has a motor 109 (FIG. 1) within a motor housing 221. Extending from the motor housing 221 is, typically, a receptacle 223 for receiving the dirt. Also within the motor housing 221 is a motor control circuit 225 embodying central control module 103 of FIG. 2. In the preferred embodiment, the motor housing 221 also acts as a motor control housing 221. Accordingly, the motor housing 221 will be referred to as a motor control housing herein, unless the context requires otherwise. It is to be understood that the motor housing and motor control housing could be separate from one another.

Preferably, the central control module 103 (including its transceiver 74) is placed within the motor control housing 221. Alternatively, the central control module 103 could be distributed with the transceiver 74 portion outside the motor housing 221 to avoid interference and signal attenuation.

The motor control circuit 225 is typically laid out on a printed circuit board 233, including all of the components to implement the functions of the central control module 103. Multiple printed circuit boards or separately mounted components may be used as desired.

The motor control circuit 225 can be mounted in many different ways, for example on mounting screws or posts, not shown, inside or outside the motor control housing. It may be preferable to mount the motor control circuit 225 in the cooling air inlet passage or outtake (exhaust) of the motor 109 to provide cooling for the circuit 225. Any power stage of the circuit 225, in particular, may benefit from such cooling.

Although the preferred embodiment is being described with reference to a motor control circuit 225 for mounting inside a motor housing 221, as mentioned previously, the circuit 225 need not be mounted inside the motor housing 221. For example, the circuit 225 could be mounted within a control box, not shown, outside the housing 221 with wires fed back into the housing 221 for operation of the motor 109. This might be done for additional isolation of the control circuit 225 from the motor 109. For example, it might be helpful to avoid electromagnetic interference from the motor 109. The control box would be an alternate form of motor control housing 221. As mentioned previously, for this reason, the motor housing 221 is being referred to as a motor control housing 221 in this description, unless the context requires otherwise.

In the preferred embodiment, the central control module 103 also has means for communication with the operator 111. In the preferred embodiment, display means 75 takes the form of an LED, not shown, within a translucent mounting post 227. The motor control circuit 225 has optional wired and wireless communication paths. Accordingly, the mounting post 227 accepts connections from low voltage wires. As an alternative display example, the LED could extend through the housing 221 for direct viewing.

LEDs are a preferred choice as LEDs are long lasting, small, inexpensive, and low power devices. Higher power LEDs, LEDs of different colours, multi-colour LEDs, and LEDs of different shapes and sizes may all be used. Standard LED packages such as a T-1 or T-1 $\frac{3}{4}$ can be used. These tend to be the least expensive. This allows for LEDs of more than 3000 mcd, for example 3200 mcd and 4500 mcd in green. These are examples only and many other sizes and configurations can be used. For example, a multi-colour LED could be used to provide many possible signaling combinations, such as a red/yellow LED that can provide red solid, red flashing, yellow solid, yellow flashing, orange solid, and orange flashing. Also, single colour LEDs can be chosen from a wide variety of colours, including green, yellow, red, white and blue, among others.

The messages provided to the user 111 by the LEDs might include, for example, 1) informing the user that electrical power is present and the system 1 has no apparent problems (LED GREEN), 2) air flow is obstructed, check for obstructions, including in the pipes 207, in the flexible hose 211 or the filter medium, or the dust receptacle 223 is full and should be emptied (LED YELLOW), 3) a sensor indicates that service to the system 201 is needed, for example, an overcurrent condition shutdown that may indicate a problem such as bearing failure (LED flashes RED), and 4) a certain amount of time has passed indicating that service to the system 201 is needed, for example: service to the motor is required, i.e. change the brushes (LED flashes YELLOW). These are samples of the types of messages that might be conveyed to the user. Many other messages could be conveyed as desired by designers of motor control circuit 225 using other colours or flashing patterns.

Referring again to FIG. 10, preferably, the ERV control module 303 (including its transceiver 374) is placed within an ERV control housing 421. Alternatively, the ERV control module 303 could be distributed with the transceiver 374 portion outside the housing 421 to avoid interference and signal attenuation.

An ERV control circuit, not shown, is typically laid out on a printed circuit board, including all of the components to implement the functions of the ERV control module 303. Multiple printed circuit boards or separately mounted components may be used as desired.

The ERV control circuit can be mounted in many different ways, for example on mounting screws or posts, not shown, inside or outside the ERV housing 421. It may be preferable to mount the ERV control circuit in the exhaust air path of the ERV 7c to provide cooling for the circuit. Any power stage of the circuit, in particular, may benefit from such cooling.

Although the preferred embodiment is being described with reference to an ERV control circuit for mounting inside a housing 421, as mentioned previously, the circuit need not be mounted inside the housing 421. For example, the circuit could be mounted within a control box, not shown, outside the housing 421 with wires fed back into the housing 421 for operation of the motors 309. This might be done for additional isolation of the control circuit from the motor 309. For example, it might be helpful to avoid electromagnetic interference from the motor 309. The control box would be an alternate form of ERV control housing 421. As mentioned previously, for this reason, the ERV housing 421 is being referred to as a motor control housing 421 in this description, unless the context requires otherwise.

Referring to FIG. 14, in a manner similar to that described for the central control module 103, the remote control module 105 is mounted in a handle, for example handle 29, typically on a printed circuit board 240. It is to be noted that other

handles, such as for example handles **200**, **213** could be used. The printed circuit board **240** and other components of the central control module **103** could be fully encapsulated with simply a couple of wires **242** extending for connection to a power source **244**. Messages are provided to the user **111** in the manner described previously herein. The messages provided to the user **111** include, for example, those previously described for the central control module **103**.

The remote control module **105** is preferably battery **244** powered; however, it may also be powered from line voltage where it is available, using a drop down resistor and capacitor. Many vacuum hoses **217** have line voltage as it is used to power hose attachments **216**, such as a power carpet brush. The battery **244** could be a rechargeable battery **244**. Batteries **244** provide energy for limited durations.

In this description an embodiment has been described wherein the central control module for the central vacuum unit interacts with an ERV to provide pressure balancing of a structure. Another embodiment has been described wherein a remote control module interacts with a central vacuum unit and with an ERV to provide pressure balancing. It is to be understood that structure from one embodiment may be transferred to the other embodiment to provide corresponding features.

In this description an embodiment has been described wherein an ERV control module contains structure providing intelligent control of the ERV following external input, for example using a timer that is activated on receipt of an external signal. It is to be recognized this intelligence could be in the remote control module **105**, such that, the remote control module calculates the relevant time and simply instructs the ERV to turn on and off, or on for certain period of time, in a mode that will provide make-up supply air. For example, it is recognized that some ERVs provide an offset mode that will provide make-up supply air. An example is the RecoupAerator™ 200DX energy recovery ventilator of UltimateAir™ Inc. of Athens, Ohio. This model provides a jumper connect to determine the offset; however, the jumper could be replaced with a controllable setting, such as through a microprocessor to allow selective activation of the offset, including an offset of zero for a balanced mode. Such a controllable setting could be utilized by any of the embodiments described herein.

Similarly, the intelligence could be in the central control module **103** and activated when the central vacuum is activated. As a further alternative, the intelligence could be distributed across the central vacuum hose handle **29**, the ERV **7c** and the central vacuum source unit **41**.

Referring again to FIG. 1, a blower (such as a fan) **500** can replace the ERV **7c** as an external air intake device. The blower **500** may be within an area **502** (for example a garage or utility room) of the structure **9** that is not in air connection to the area **504** (for example an upper floor room) being vacuumed at the time of air replenishment. If so, the blower **500** can be connected to the forced air ductwork **400** in a similar manner to that described for the blower **309c** of FIG. 10. The blower **500** can then be controlled in a manner similar to the blower **309c**, for example utilizing an appliance communication module **5** similar to that described for use in association with the ERV **7c**. Again, it is to be recognized that the control could be through a wired connection to the blower **500**. The control intelligence could be at the blower **500** or in the central vacuum system as discuss previously.

The blower **500** may also be located in an area **506** that is in air communication with the area **502** being vacuumed, for example another room in a main part of the structure **9**. In this case, a simple air replenishment system may be implemented without ductwork **400** by simply allowing make-up air from

the blower **500** to flow into the area **506** directly. Air pressure in the structure **9** then equalizes on its own. Air connection for pressure equalization within the structure **9** may also occur through air connection provided by operation of any air handling equipment in the structure **9** and associated ductwork that is in air connection with areas **502**, **506**. Although it is preferable that the areas **506**, **502** are in air contact at the time that make-up air is drawn into the structure **9**, this can be allowed to occur at a later time, for example when doors are opened between the areas **502**, **506**.

Similarly, the blower **500** can be replaced by an air intake device **600** that utilizes pressure differential to draw in make-up air to the structure **9**. Such a device **600** is, for example, a damper **600** that opens and closes air connection between internal and external air for the structure **9**. After use of the central vacuuming system, the damper **600** can be open to allow pressure equalization between internal and external air. The damper **600** will need to be located in an area **506** that is in air connection with the vacuumed area **502** in order for any lower pressure in the area **502** to draw in make-up air through the open damper **600**, for example utilizing an appliance communication module **5** similar to that described for use in association with the ERV **7c**. Again, it is to be recognized that the control could be through a wired connection to the damper **600**. Again, operation of the damper **600** can be controlled in a manner similar to that of the blower **309c**. The control intelligence could be at the damper **600** or in the central vacuum system as discuss previously. The damper **600** may, as an example, take the form of a motorized flap.

It is to be recognized that each of the example embodiments for intake of supply air include air intake devices, for example the ERV **7c**, the blower **500** and the damper **600** are all air intake devices.

It is to be recognized that although this description is made with reference to central vacuum cleaning systems, many of the functions will also apply to portable vacuum cleaning systems such as canister vacuum cleaners and upright vacuum cleaners as will be evident to those skilled in the art. It is recognized that the pressure balancing embodiments of the description are unlikely to be applied to non-central vacuum applications as air is not typically exhausted in those applications. In many central vacuum cleaner system installations air is not exhausted from the structure, but to an area of the structure outside of the main living space, for example to an attached garage where the central vacuum source is located. Make-up air to the structure for the main living space can still be beneficial in these installations.

It will be understood by those skilled in the art that this description is made with reference to the preferred embodiment and that it is possible to make other embodiments employing the principles of the invention which fall within its spirit and scope as defined by the following claims.

I claim:

1. A vacuum cleaning system for use in a structure, the system comprising:

- a) a receiver adapted to receive communication that an appliance has been activated, and
- b) a control circuit adapted to turn off the central vacuum cleaning system upon receipt of a communication at the receiver that the appliance has been activated, wherein the appliance is a telephone and the telephone is activated when there is an incoming call on the telephone.

2. The system of claim 1 wherein the control circuit is adapted to turn off the cleaning system when there is an incoming telephone call.

17

3. The system of claim 1 further comprising an adapter adapted to sense activation of the appliance and transmit a communication to the receiver.

4. The system of claim 3 wherein the adapter is a telephone line adaptor adapted to sense incoming calls on the telephone line.

5. The system of claim 1 wherein the receiver is a wireless radio frequency receiver and the communications are wireless radio frequency communicators.

6. A vacuum cleaning system for use in a structure, the system comprising:

- a) a receiver adapted to receive communication that an appliance has been activated, and
- b) a control circuit adapted to turn off the central vacuum cleaning system upon receipt of a communication at the receiver that the appliance has been activated,

wherein the appliance is a doorbell.

7. The system of claim 6 wherein the control circuit is adapted to turn off the cleaning system when the doorbell is activated.

18

8. The system of claim 6 further comprising an adapter adapted to sense activation of the appliance and transmit a communication to the receiver.

9. The system of claim 6 wherein the receiver is a wireless radio frequency receiver and the communications are wireless radio frequency communicators.

10. A method of controlling a central vacuum cleaning system comprising:

- receiving communications at the central vacuum cleaning system when there is an incoming telephone call to a telephone, and
- controlling the central vacuum cleaning system to turn off the system upon receipt of the communications.

11. The system of claim 8 wherein the adapter is a doorbell adapter adapted to sense activation of the doorbell.

12. A method of controlling a central vacuum cleaning system comprising:

- receiving communications at the central vacuum cleaning system when a doorbell is activated, and
- controlling the central vacuum cleaning system to turn off the system upon receipt of the communications.

* * * * *