



US008516653B2

(12) **United States Patent**  
**Cunningham et al.**

(10) **Patent No.:** **US 8,516,653 B2**  
(45) **Date of Patent:** **Aug. 27, 2013**

(54) **CLEANER HANDLE AND CLEANER HANDLE HOUSING SECTIONS**  
(75) Inventors: **J. Vern Cunningham**, Aurora (CA);  
**Paul Charlebois**, Toronto (CA);  
**Tasneem Babul Rayani**, Waterloo (AU);  
**Paul Arato**, Toronto (CA)

(73) Assignee: **Cube Investments Limited**, Aurora (CA)

(\* ) Notice: Subject to any disclaimer, the term of this patent is extended or adjusted under 35 U.S.C. 154(b) by 1510 days.

(21) Appl. No.: **11/662,495**

(22) PCT Filed: **Sep. 16, 2005**

(86) PCT No.: **PCT/CA2005/001420**

§ 371 (c)(1),  
(2), (4) Date: **Mar. 15, 2007**

(87) PCT Pub. No.: **WO2006/029535**

PCT Pub. Date: **Mar. 23, 2006**

(65) **Prior Publication Data**

US 2008/0301903 A1 Dec. 11, 2008

**Related U.S. Application Data**

(60) Provisional application No. 60/610,557, filed on Sep. 17, 2004.

(51) **Int. Cl.**  
**A47L 9/32** (2006.01)

(52) **U.S. Cl.**  
USPC ..... **15/339**; 15/410

(58) **Field of Classification Search**  
USPC ..... 15/339, 377, 319, 324, 314, 301,  
15/410

See application file for complete search history.

(56) **References Cited**

U.S. PATENT DOCUMENTS

1,601,531 A 9/1926 Jeannin  
1,883,288 A 10/1932 Zubaty

(Continued)

FOREIGN PATENT DOCUMENTS

EP 0192469 8/1986  
EP 0347223 12/1989

(Continued)

OTHER PUBLICATIONS

Japan Patent Office, English translation of abstract only of publication No. JP02152419, Floor Nozzle for Vacuum Cleaner, publication date Jun. 12, 1990.

(Continued)

*Primary Examiner* — Robert Scruggs

(57) **ABSTRACT**

Handle has status indicators viewable by operator while viewing location being cleaned and using handle in ordinary cleaning position, and light illuminating location being cleaned. Indicators are LED lamps. Light is an LED lamp. Microphone senses particles and illuminates an indicator. Indicators and light are provided in a housing section that forms part of a housing for handle. Housing section may be integrated with the remainder of the housing, or may be unit that fits into remainder of housing. Light has central axis generally parallel, within approximately five degrees from parallel, with cleaning axis of handle. Indicators each have a central axis generally parallel, within approximately 5 degrees from parallel, with cleaning axis of handle. The indicators have limited beam angle. Indicator viewable over grasping section of handle from towards distal end of handle. The cleaner may be a vacuum cleaner, which may be a central vacuum cleaner.

**35 Claims, 15 Drawing Sheets**

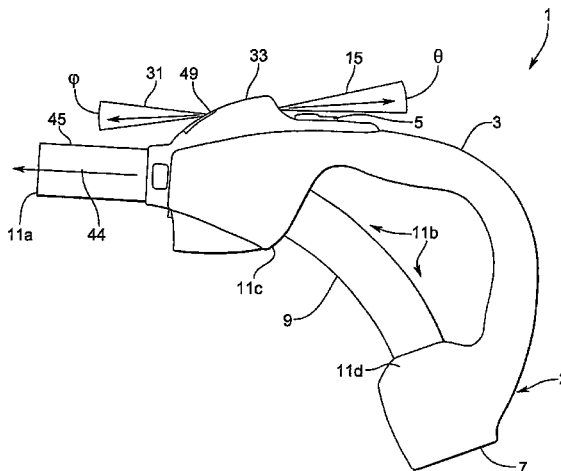

(56)

References Cited

U.S. PATENT DOCUMENTS

3,088,484	A	5/1963	Marsh	5,276,939	A	1/1994	Uenishi
3,357,039	A	12/1967	Hayward	5,277,468	A	1/1994	Blatt et al.
3,382,524	A	5/1968	Sandstrom	5,298,821	A	3/1994	Michel
3,477,689	A	11/1969	Berghoefer	5,301,385	A	4/1994	Abe et al.
3,483,503	A	12/1969	Pardiso	5,311,639	A	5/1994	Boshier
3,565,103	A	2/1971	Maselek	5,343,590	A	9/1994	Radabaugh
3,570,809	A	3/1971	Stuy	5,347,186	A	9/1994	Konotchick
3,626,545	A	12/1971	Sparrow	5,349,146	A	9/1994	Radabaugh
3,628,769	A	12/1971	Lee	5,353,468	A	10/1994	Yap et al.
3,661,356	A	5/1972	Tucker	5,363,534	A	11/1994	Dekker et al.
3,663,845	A	5/1972	Apstein	5,379,796	A	1/1995	Wang
3,676,986	A	7/1972	Reiling	5,391,064	A	2/1995	Lopez
3,826,464	A	7/1974	Berghofer	5,404,612	A	4/1995	Ishikawa
3,855,665	A	12/1974	Schwartz	5,409,398	A	4/1995	Chadbourne et al.
3,965,526	A	6/1976	Doubleday	5,448,827	A	9/1995	Ward
3,989,311	A*	11/1976	Debrey ..... 406/36	D364,014	S	11/1995	Langeland et al.
4,056,334	A	11/1977	Fortune	5,479,676	A	1/1996	Martin et al.
4,070,586	A	1/1978	Breslin	5,504,971	A	4/1996	McCormick
4,111,615	A	9/1978	Watanabe	5,512,883	A	4/1996	Lane, Jr.
4,114,557	A	9/1978	De Brey	5,515,572	A	5/1996	Hoekstra et al.
4,175,892	A	11/1979	De Brey	5,525,842	A	6/1996	Leininger
4,225,272	A	9/1980	Palmovist	5,542,146	A	8/1996	Hoekstra et al.
4,227,258	A	10/1980	Root et al.	5,554,049	A	9/1996	Reynolds
4,246,675	A	1/1981	Costanzo	5,560,076	A	10/1996	Leung
4,300,262	A	11/1981	Rodowsky, Jr. et al.	5,568,374	A	10/1996	Lindeboom et al.
4,336,427	A	6/1982	Lindsay	5,572,767	A	11/1996	Ishikawa
4,368,348	A	1/1983	Eichelberger et al.	5,578,795	A	11/1996	Ward
4,369,543	A	1/1983	Chen et al.	5,606,767	A	3/1997	Crienjak
4,370,776	A	2/1983	Kullik	5,655,884	A	8/1997	Rose
4,443,906	A	4/1984	Tucker et al.	5,698,957	A	12/1997	Sowada
4,473,923	A	10/1984	Neroni et al.	5,713,656	A	2/1998	Lin
4,490,575	A	12/1984	Kutnyak	5,722,110	A	3/1998	McIntyre et al.
4,494,270	A	1/1985	Ritzau et al.	5,737,797	A	4/1998	Rittmueller et al.
4,513,469	A	4/1985	Godfrey et al.	5,737,798	A	4/1998	Moren et al.
4,531,796	A	7/1985	Gansert et al.	5,740,581	A	4/1998	Harrelson, II
4,536,674	A	8/1985	Schmidt	5,740,582	A	4/1998	Harrelson, II
4,591,368	A	5/1986	MacDuff	5,747,973	A	5/1998	Robitaille et al.
4,611,365	A	9/1986	Komatsu et al.	5,753,989	A	5/1998	Syverson et al.
4,654,924	A	4/1987	Getz et al.	5,813,085	A	9/1998	Fritz et al.
4,664,457	A	5/1987	Suchy	5,815,883	A	10/1998	Stein et al.
4,680,827	A	7/1987	Hummel	5,815,884	A*	10/1998	Imamura et al. .... 15/339
4,683,515	A	7/1987	Beihoff et al.	5,816,685	A	10/1998	Hou
4,688,596	A	8/1987	Liebmann et al.	5,850,665	A	12/1998	Bousset
4,693,324	A	9/1987	Choiniere et al.	5,871,152	A	2/1999	Saney
4,731,545	A	3/1988	Lerner et al.	D406,422	S	3/1999	Burchard et al.
4,757,574	A	7/1988	Sumerau	5,896,618	A	4/1999	Woo et al.
4,766,628	A	8/1988	Walker	5,917,428	A	6/1999	Discenzo et al.
4,791,700	A	12/1988	Bigley et al.	5,918,728	A	7/1999	Syverson
4,829,625	A*	5/1989	Wang ..... 15/422.2	5,924,163	A	7/1999	Burns, Jr.
4,829,626	A	5/1989	Harkonen et al.	5,924,164	A	7/1999	Lindsay, Jr.
4,854,887	A	8/1989	Blandin	5,926,908	A	7/1999	Lindsay, Jr.
4,881,909	A	11/1989	Blackman	5,926,909	A	7/1999	McGee
4,883,982	A	11/1989	Forbes et al.	5,938,061	A	8/1999	Ward et al.
D315,043	S	2/1991	Hayden	5,945,749	A	8/1999	Li
4,991,253	A	2/1991	Rechsteiner	5,983,443	A	11/1999	Redding
5,033,151	A	7/1991	Kraft et al.	5,987,697	A	11/1999	Song et al.
5,067,394	A	11/1991	Cavallero	6,029,309	A	2/2000	Imamura
5,068,555	A	11/1991	Oberdorfer-Bogel	6,033,082	A	3/2000	Lin
5,107,565	A	4/1992	Chun	6,049,143	A	4/2000	Simpson et al.
5,109,568	A	5/1992	Rohn et al.	6,101,667	A	8/2000	Ishikawa
5,111,841	A	5/1992	Houston	D431,335	S	9/2000	Mehaffey et al.
5,120,983	A	6/1992	Samann	6,169,258	B1	1/2001	Roney et al.
5,125,125	A	6/1992	Barsacq	6,206,181	B1	3/2001	Syverson
D333,023	S	2/1993	Herron, Jr.	6,218,798	B1	4/2001	Price et al.
5,185,705	A	2/1993	Farrington	6,232,696	B1	5/2001	Kim et al.
D334,447	S	3/1993	Rohn	6,239,576	B1	5/2001	Breslin et al.
5,191,673	A	3/1993	Damizet	6,244,427	B1	6/2001	Syverson
5,207,498	A	5/1993	Lawrence et al.	6,253,414	B1	7/2001	Bradd et al.
5,244,409	A	9/1993	Guss et al.	6,256,833	B1	7/2001	Steinberg
5,255,409	A	10/1993	Fujiwara et al.	6,323,570	B1	11/2001	Nishimura et al.
5,263,502	A	11/1993	Dick	6,336,825	B1	1/2002	Seefried
5,265,305	A*	11/1993	Kraft et al. .... 15/319	6,425,293	B1	7/2002	Woodroffe et al.
5,274,578	A	12/1993	Noeth	6,459,056	B1	10/2002	Graham
5,274,878	A*	1/1994	Radabaugh et al. .... 15/314	6,463,368	B1	10/2002	Feiten et al.
5,276,434	A	1/1994	Brooks et al.	6,488,475	B2	12/2002	Murata et al.
				6,546,814	B1	4/2003	Choe et al.
				6,628,019	B2	9/2003	Carroll
				6,658,325	B2	12/2003	Zweig
				6,685,491	B2	2/2004	Gergek

6,690,804 B2	2/2004	Everett	JP	6-277167	10/1994
D494,332 S	8/2004	Schroeter	JP	7-095944	11/1995
D494,333 S	8/2004	Schroeter	JP	7-322980	12/1995
6,779,228 B2	8/2004	Plomteux et al.	JP	8-033596	2/1996
6,791,205 B2	9/2004	Woodbridge	JP	8-117165	5/1996
6,817,058 B1	11/2004	Harrelson, II	JP	8-065876	8/1996
6,822,353 B2	11/2004	Koga et al.	JP	8-240329	9/1996
6,864,594 B2	3/2005	Seki	JP	9-149871	10/1997
6,900,565 B2	5/2005	Preston	JP	10-094504	4/1998
6,975,043 B2	12/2005	Schumacher et al.	JP	2000-116577	4/2000
6,975,993 B1	12/2005	Lin	JP	2001-137158	5/2001
7,051,398 B2	5/2006	Smith et al.	JP	2002-078656	3/2002
7,080,425 B2	7/2006	Smith et al.	JP	2002-320577	5/2002
7,114,216 B2	10/2006	Stephens et al.	JP	2003-235767	8/2003
7,122,921 B2	10/2006	Hall et al.	JP	2005-102465	4/2005
7,237,298 B2	7/2007	Reindle et al.	JP	2009-058919	3/2009
7,269,877 B2	9/2007	Tondra et al.	WO	97/37423	10/1997
7,328,479 B2	2/2008	Willenbring	WO	97/41631	11/1997
7,331,083 B2	2/2008	Overvaag et al.	WO	98/35160	8/1998
7,342,372 B2	3/2008	Jonsson et al.	WO	99/09875	3/1999
7,363,679 B2	4/2008	Zimmerle et al.	WO	99/56606	11/1999
7,403,360 B2	7/2008	Cunningham et al.	WO	00/64323	11/2000
7,406,744 B2	8/2008	Bruneau	WO	2005/031169	4/2005

2002/0001190 A1	1/2002	Everett		
2002/0127916 A1	9/2002	Zhang		
2002/0152576 A1	10/2002	Murray et al.		
2003/0044243 A1	3/2003	Tisdale		
2003/0140443 A1	7/2003	Najm		
2003/0196293 A1	10/2003	Ruff		
2004/0031506 A1*	2/2004	Tsai	134/105	
2004/0049868 A1	3/2004	Ng		
2004/0144633 A1*	7/2004	Gordon et al.	200/308	
2004/0150271 A1	8/2004	Koga et al.		
2004/0172782 A1	9/2004	Smith et al.		
2004/0177468 A1	9/2004	Smith et al.		
2004/0231090 A1	11/2004	Kushida et al.		
2004/0261211 A1	12/2004	Overvaag et al.		
2005/0022329 A1	2/2005	Harman et al.		
2005/0022337 A1	2/2005	Roney et al.		
2005/0166351 A1	8/2005	Cunningham et al.		
2005/0236012 A1	10/2005	Josefsson et al.		
2005/0245194 A1	11/2005	Hayes et al.		
2005/0254185 A1	11/2005	Cunningham		
2007/0017057 A1	1/2007	Zimmerle et al.		
2007/0283521 A1	12/2007	Foster et al.		
2008/0066252 A1	3/2008	Herron, Jr.		
2008/0222836 A1	9/2008	Cunningham		
2008/0301903 A1	12/2008	Cunningham et al.		

FOREIGN PATENT DOCUMENTS

EP	0552978	7/1993
EP	0499235	9/1995
EP	0711023	5/1996
EP	0773619	5/1997
GB	2281507	3/1995
GB	2288115	10/1995
JP	53-58160	5/1978
JP	53-128158	11/1978
JP	60-26494	9/1985
JP	64-049526	2/1989
JP	2-152420	6/1990
JP	5-003839	1/1993
JP	5-317213	3/1993

OTHER PUBLICATIONS

Japan Patent Office, English translation of abstract only of publication No. JP04017830, Vacuum Cleaner, publication date Jan. 22, 1992.

Japan Patent Office, English translation of abstract only of publication No. JP04017831, Vacuum Cleaner, publication date Jan. 22, 1992.

Extended European Search Report for EP 05788490.0, dated Jul. 13, 2009.

Audioetccetera, Wireless Remote Control for FilteX Vacuum Systems, <http://www.audio-etcetera.com/prod.html/icOid/135540>.

Central Vacuum Systems Owners Guide, M&S Systems.

Heritage Central Vacuum, Crush Proof Hoses Non-Electric, <http://www.heritagevac.com/hosesnonelectric.html>, printed Sep. 21, 2005, pp. 4, Azusa, USA.

International Search Report for PCT/CA2005/001420 dated Jan. 6, 2006.

International Search Report of PCT/CA2006/001436 dated Dec. 27, 2006.

International Preliminary Report on Patentability & Written Opinion of the International Search Authority from PCT/CA2005/001420 dated Jan. 9, 2007.

New Central Vacuum Breaks Home Automation Barrier, Business Wire dated Feb. 26, 2002.

The Eureka Company, Cordless, Rechargeable Vacuum Cleaner, Household Type, Owner's Guide, Model 570, 2000, pp. 12, Bloomington, USA.

The Eureka Company, Cordless, Rechargeable Vacuum Cleaner, Household Type, Owner's Guide, Model 96B, 2001, pp. 12, Bloomington, USA.

Ultimate Air Inc., The UltimateAir RecoupAerator 200DX Energy Recovery Ventilator, Owner's Manual and Installation Guide, Jan. 24, 2006, pp. i-iv, 1-41 Athens, USA.

\* cited by examiner

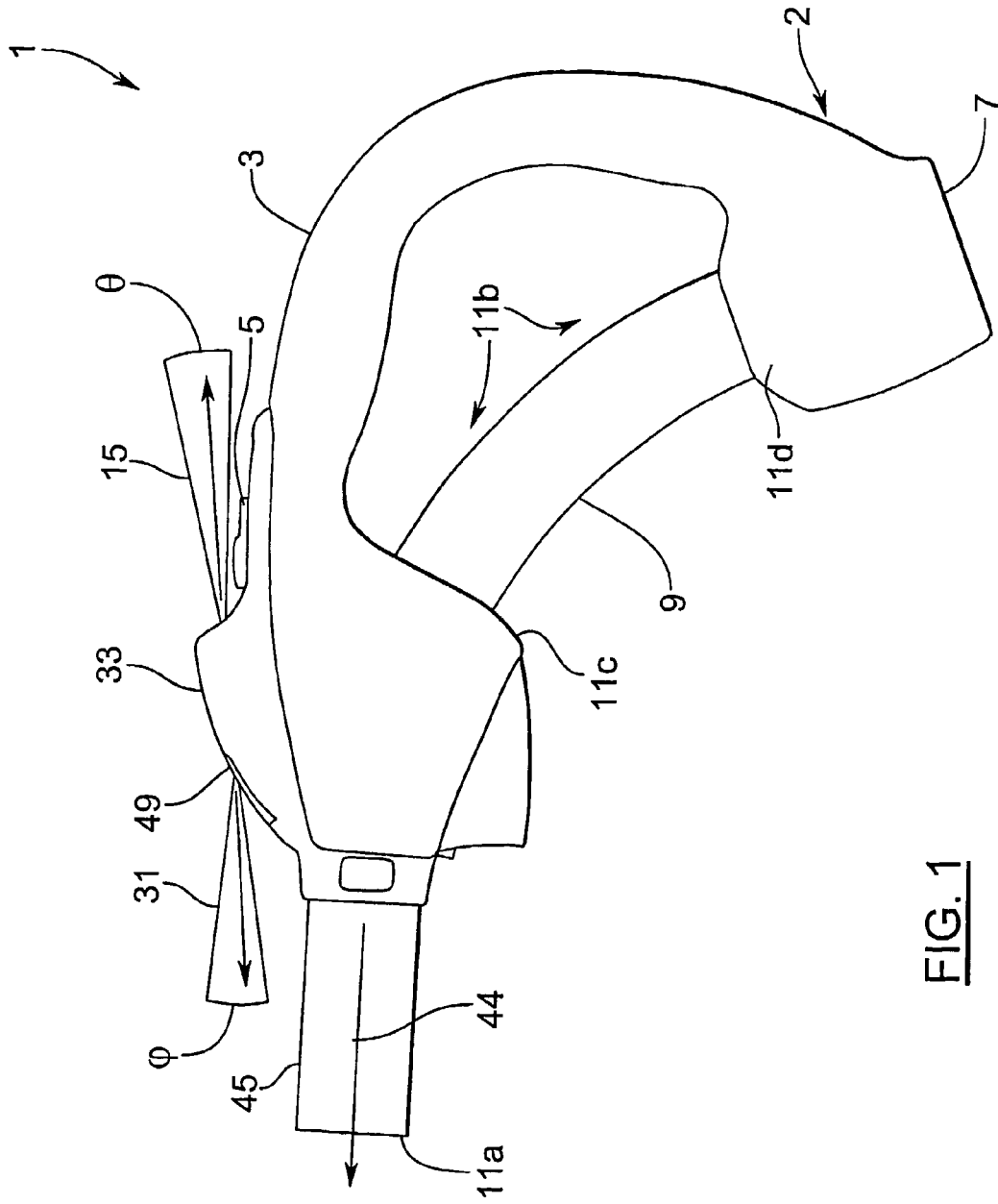

FIG. 1

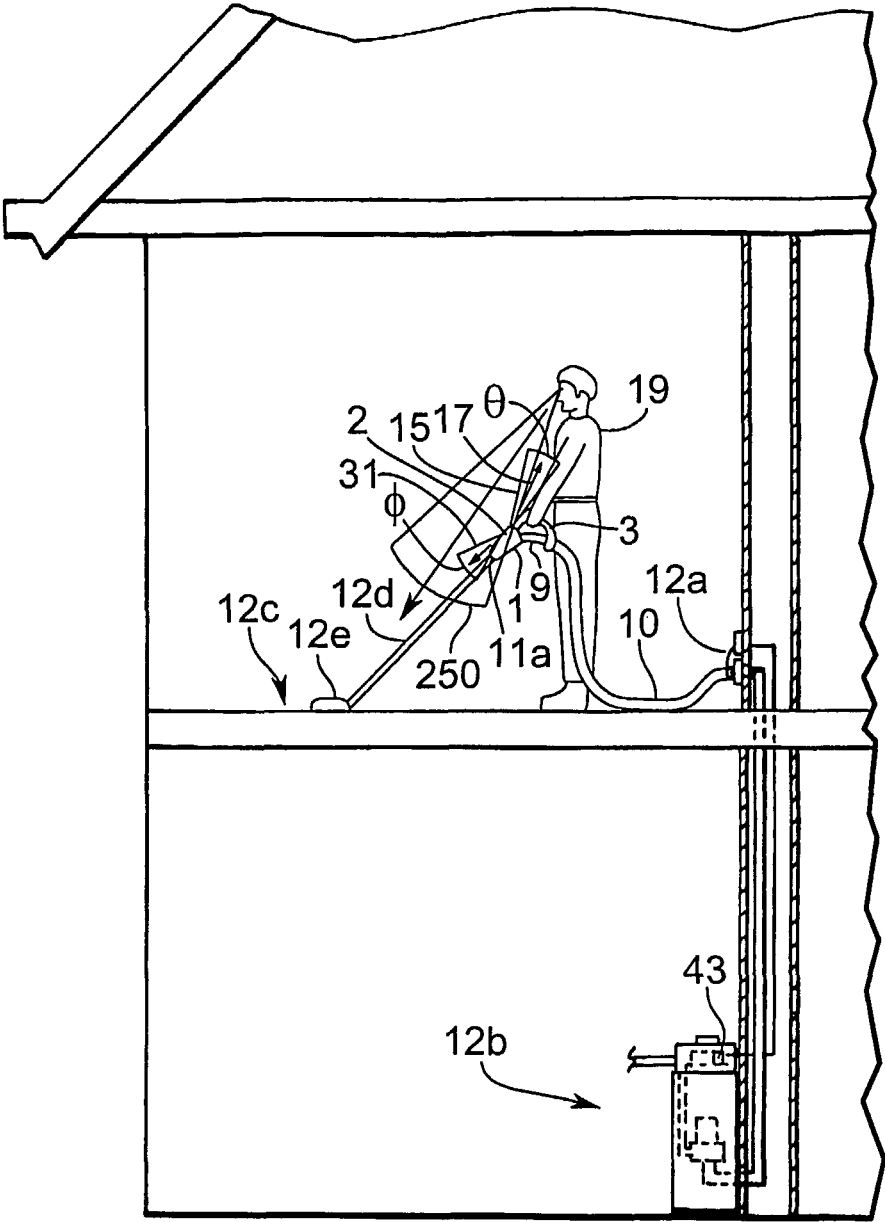

FIG. 2

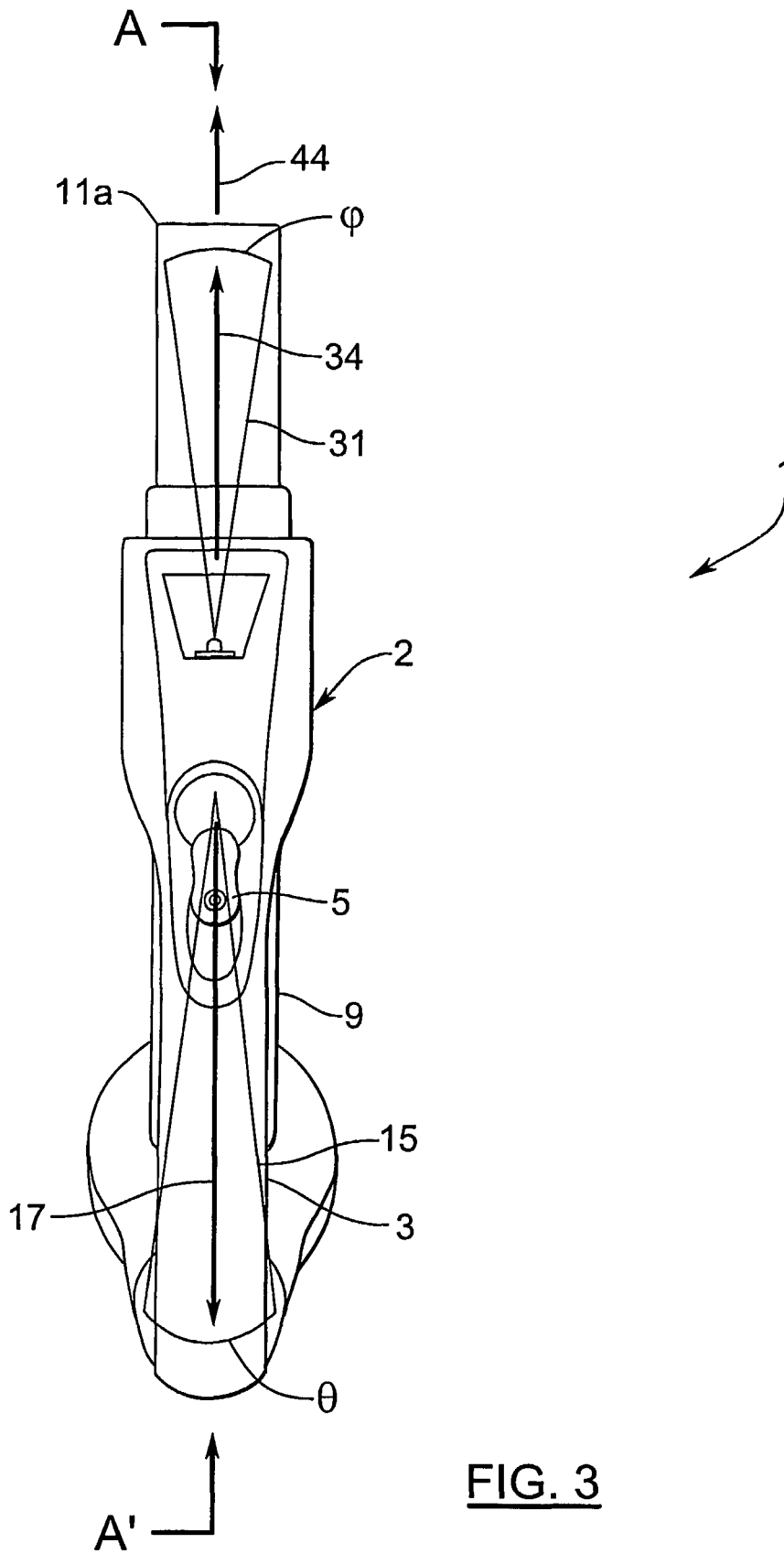
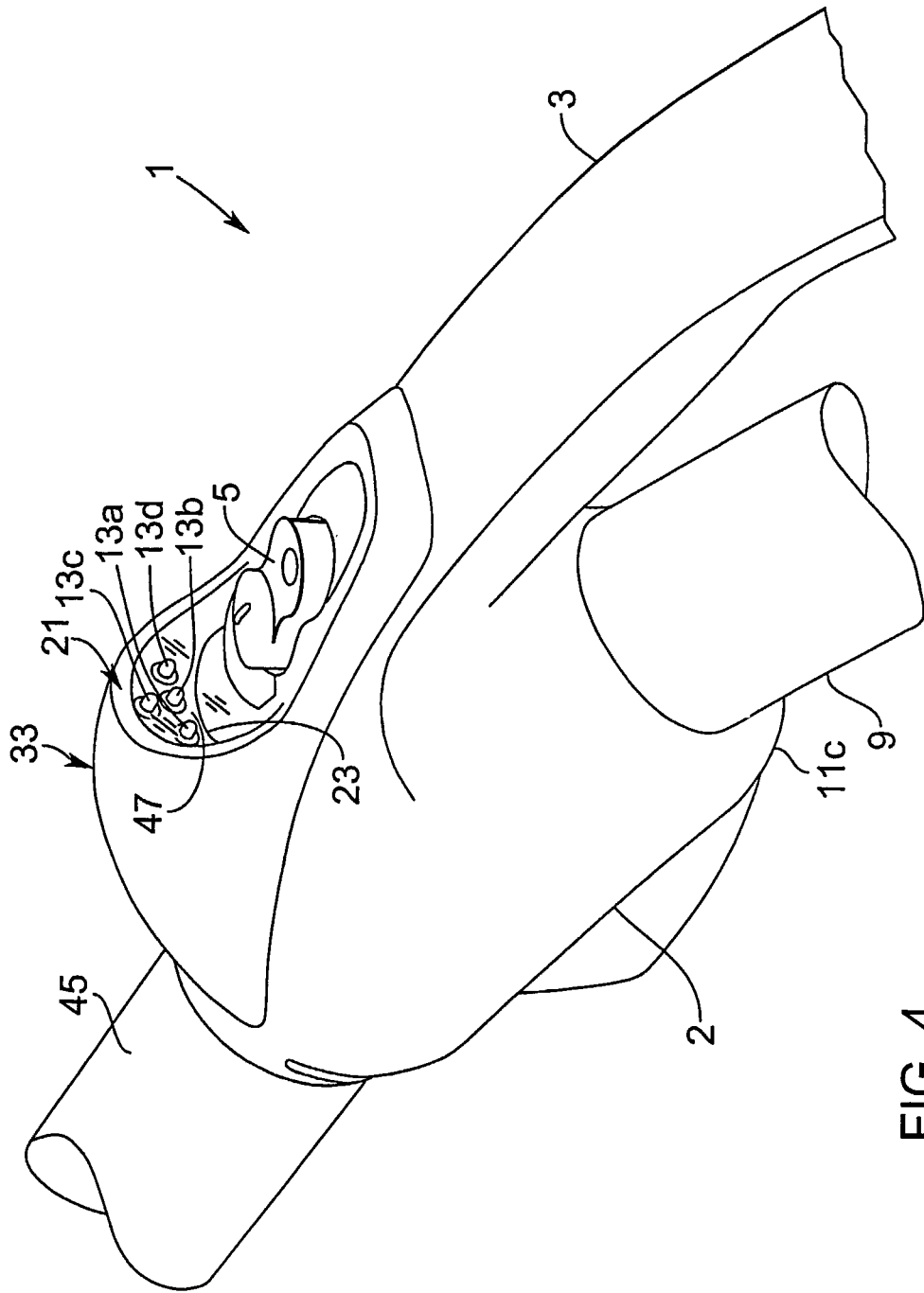

FIG. 3



**FIG. 4**

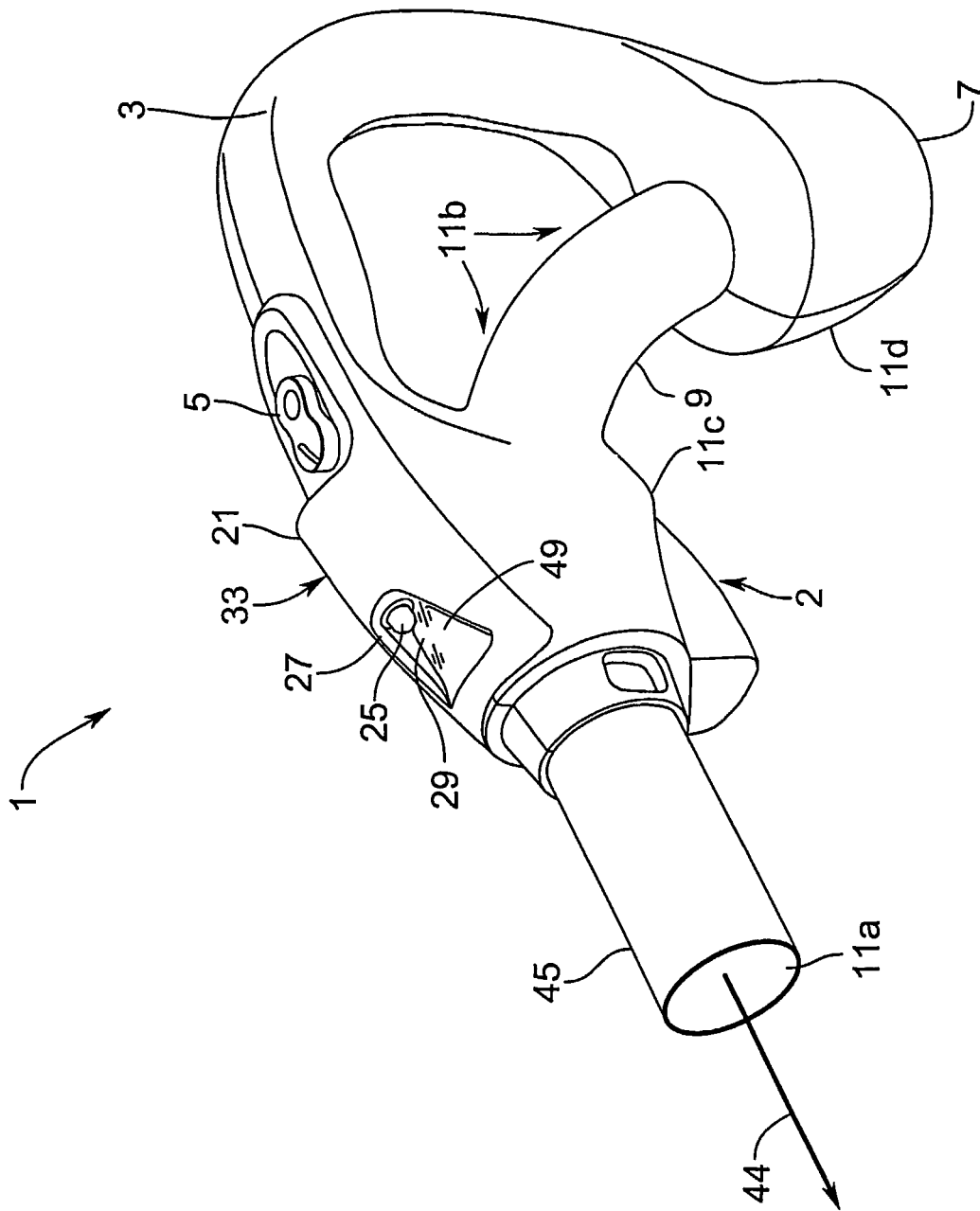

FIG. 5



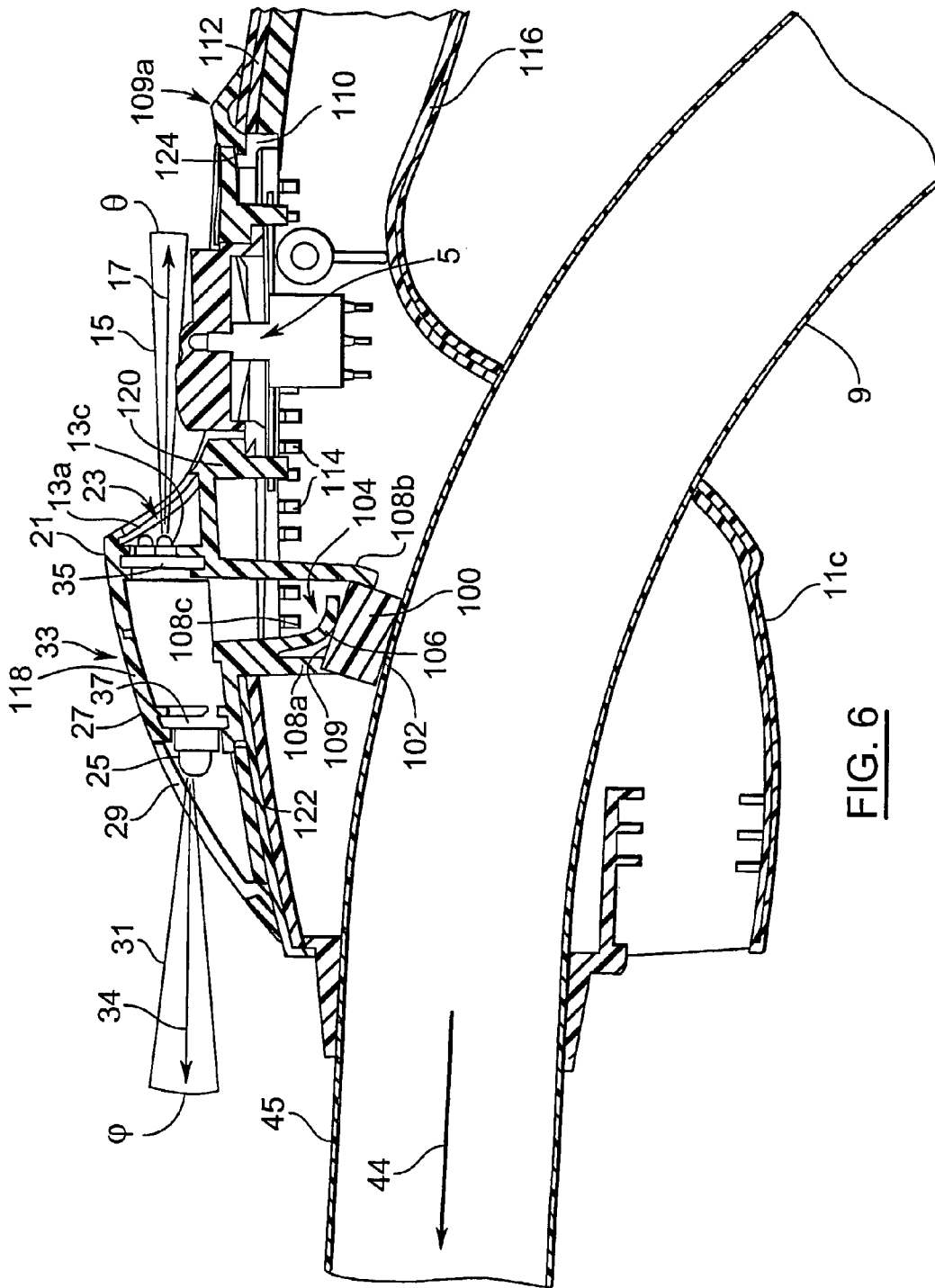

FIG. 6

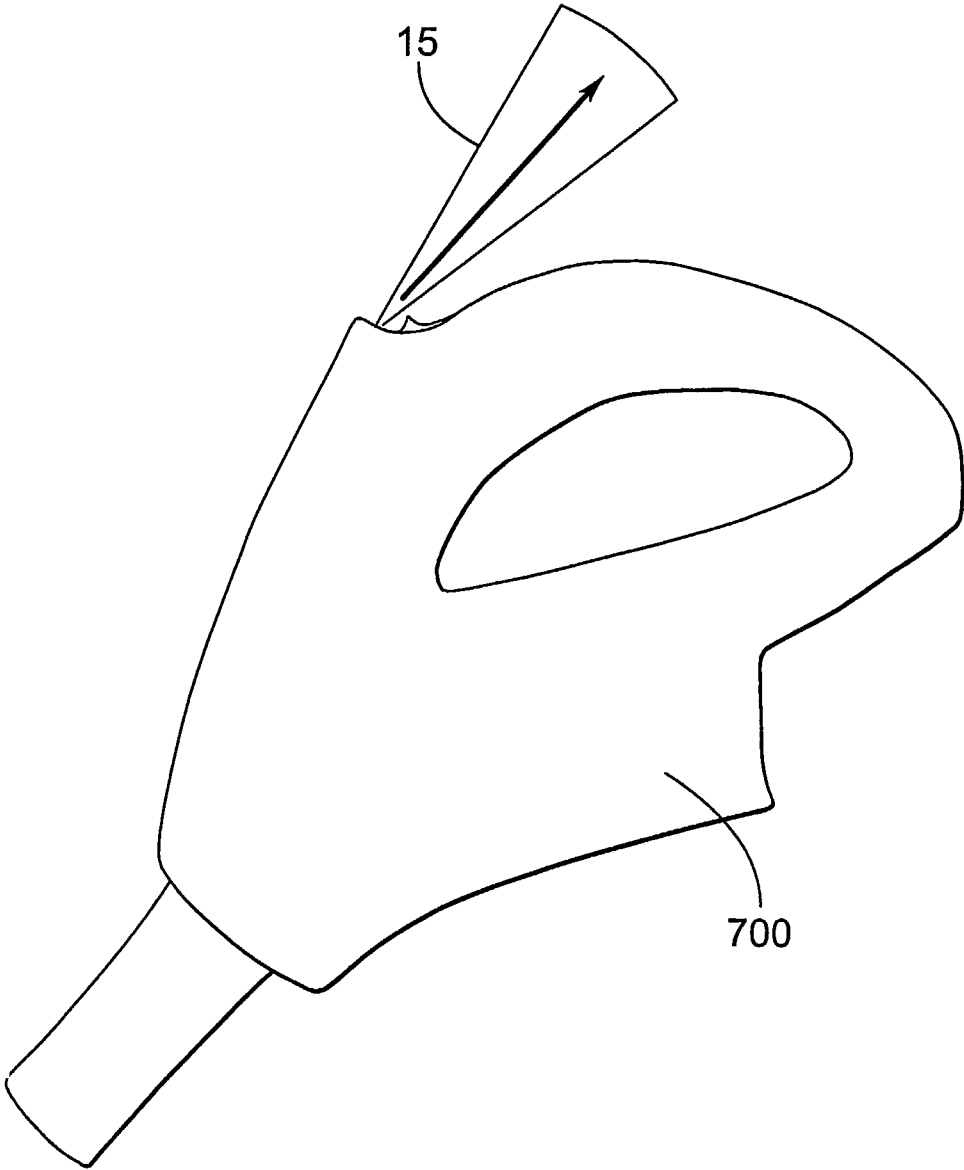

FIG. 7

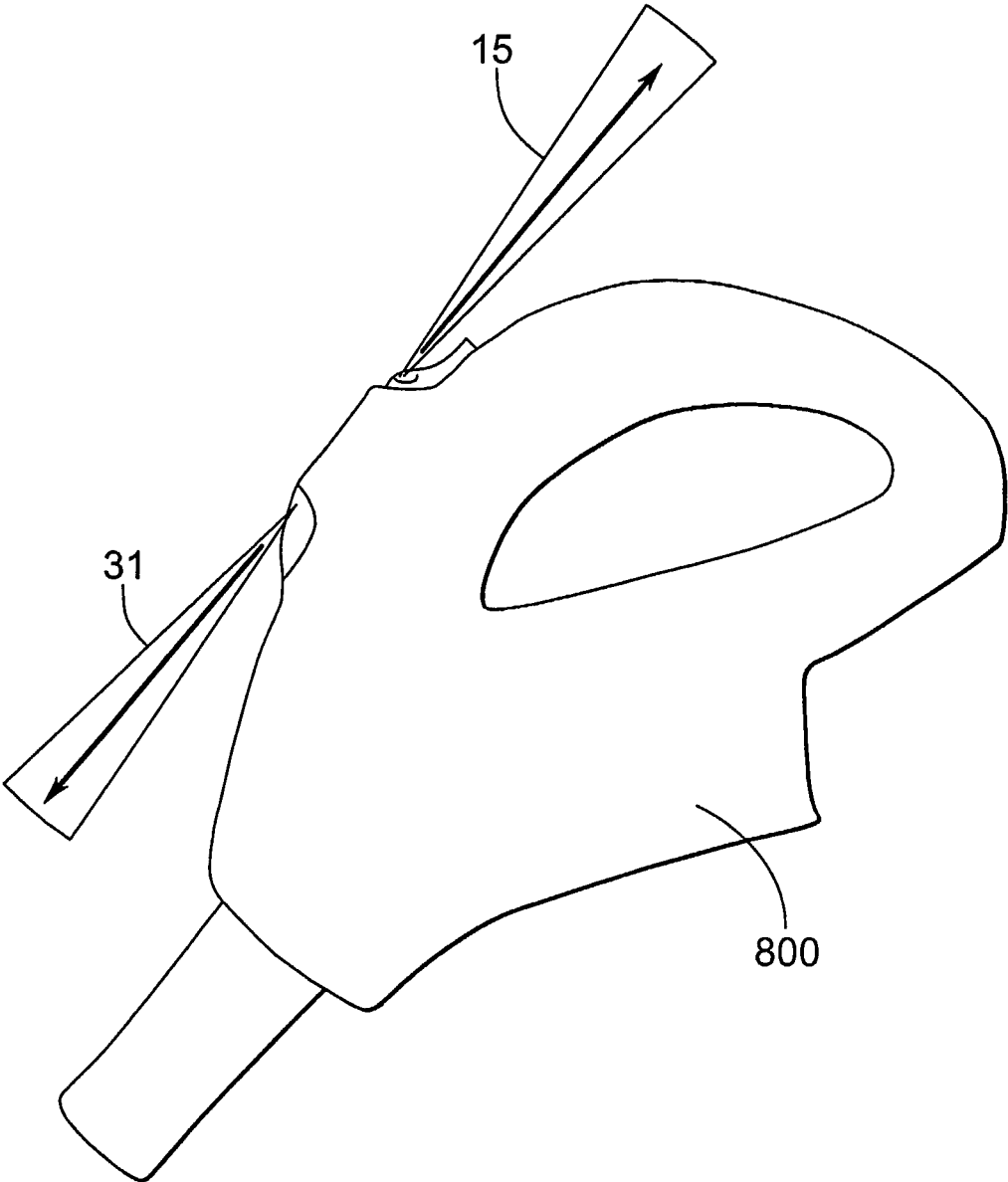

FIG. 8

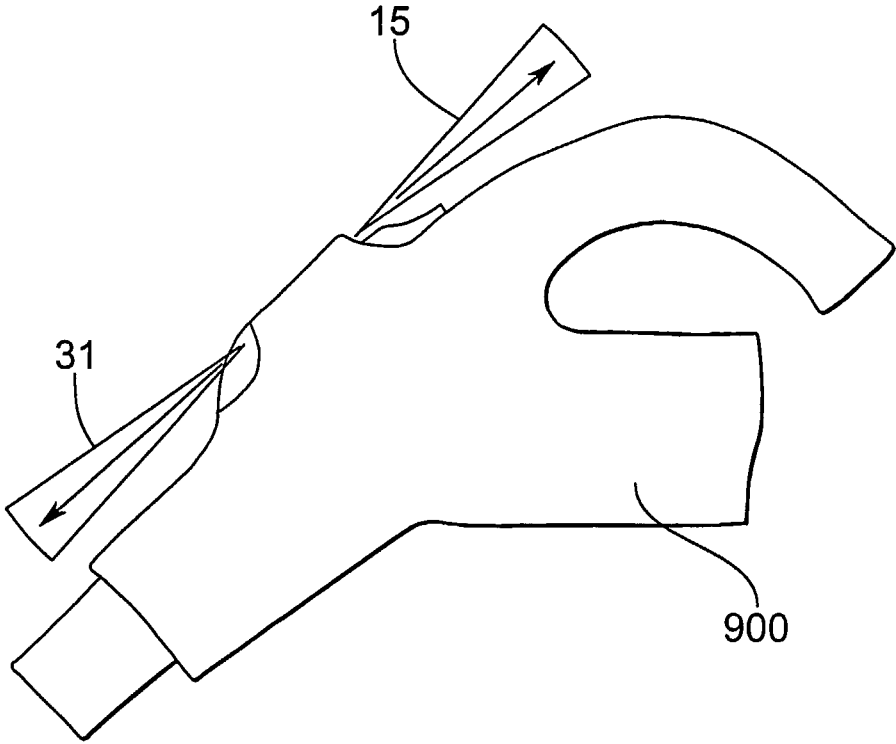

FIG. 9

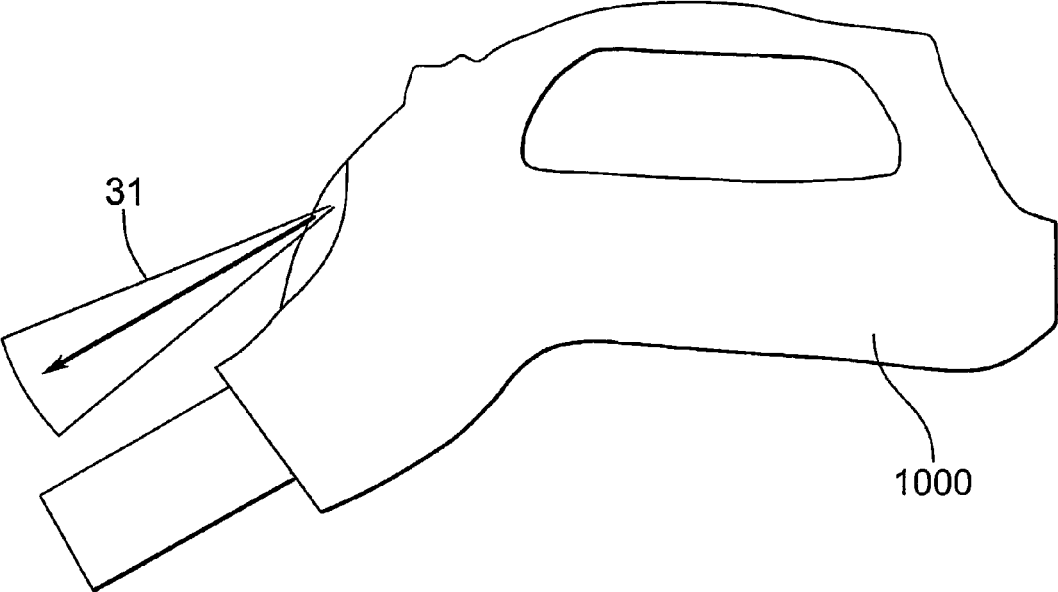

FIG. 10

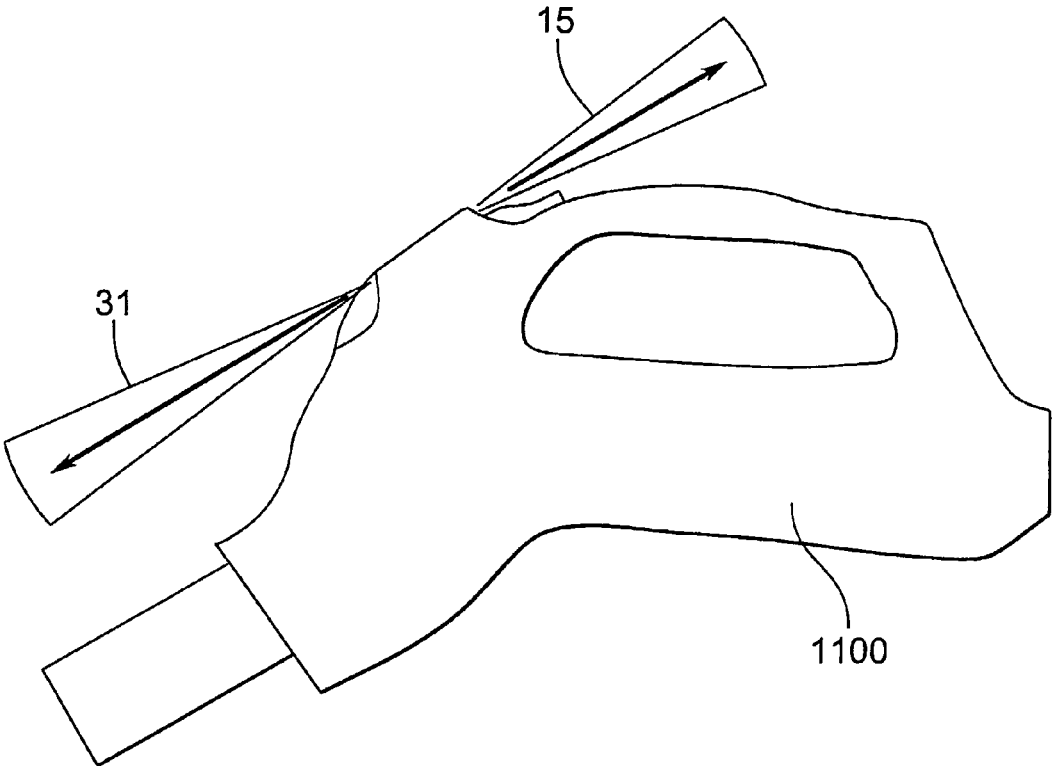

FIG. 11

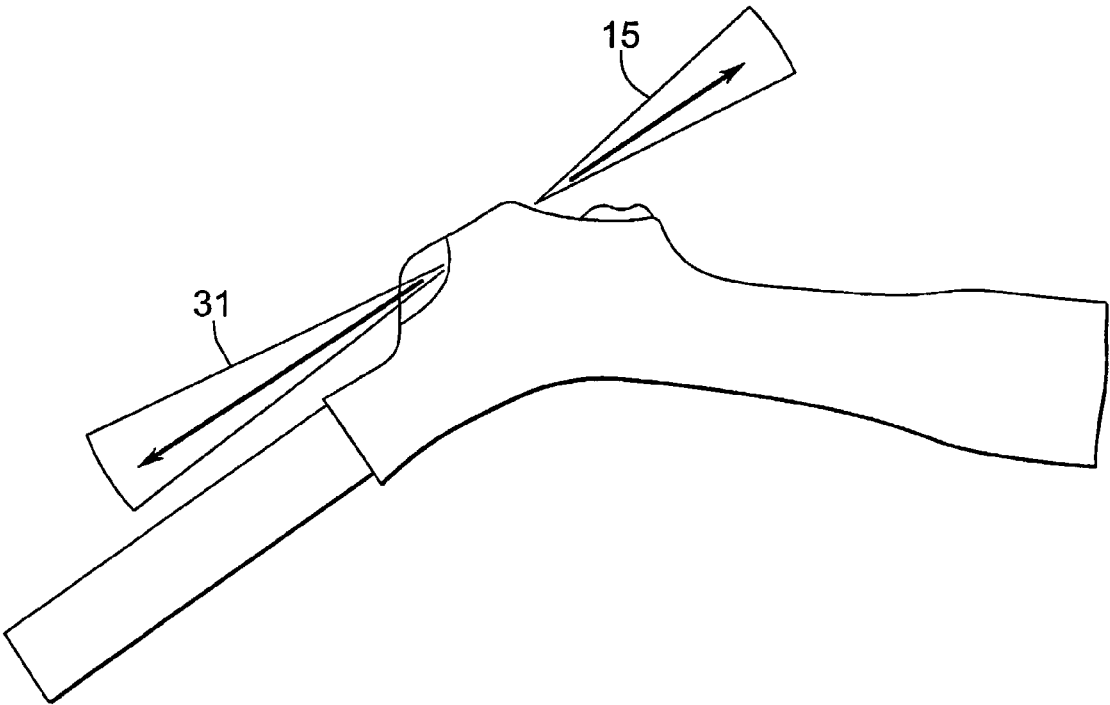

FIG. 12

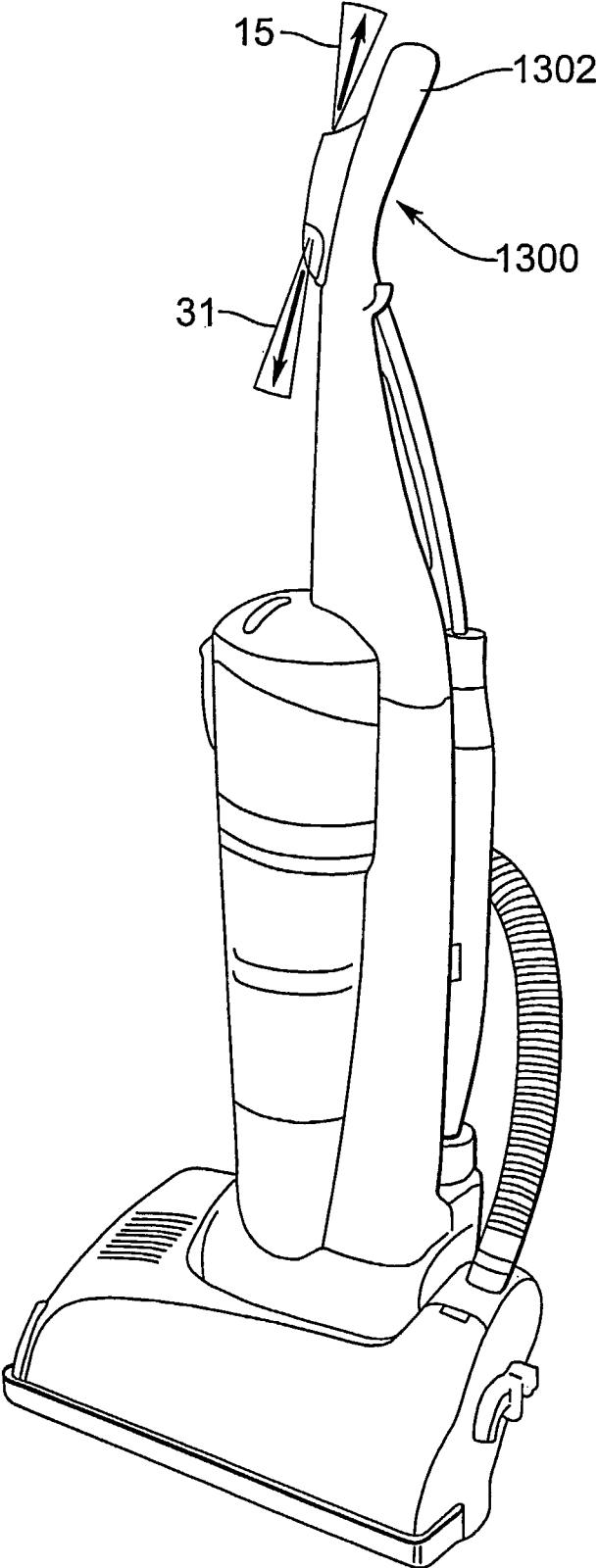

FIG.13



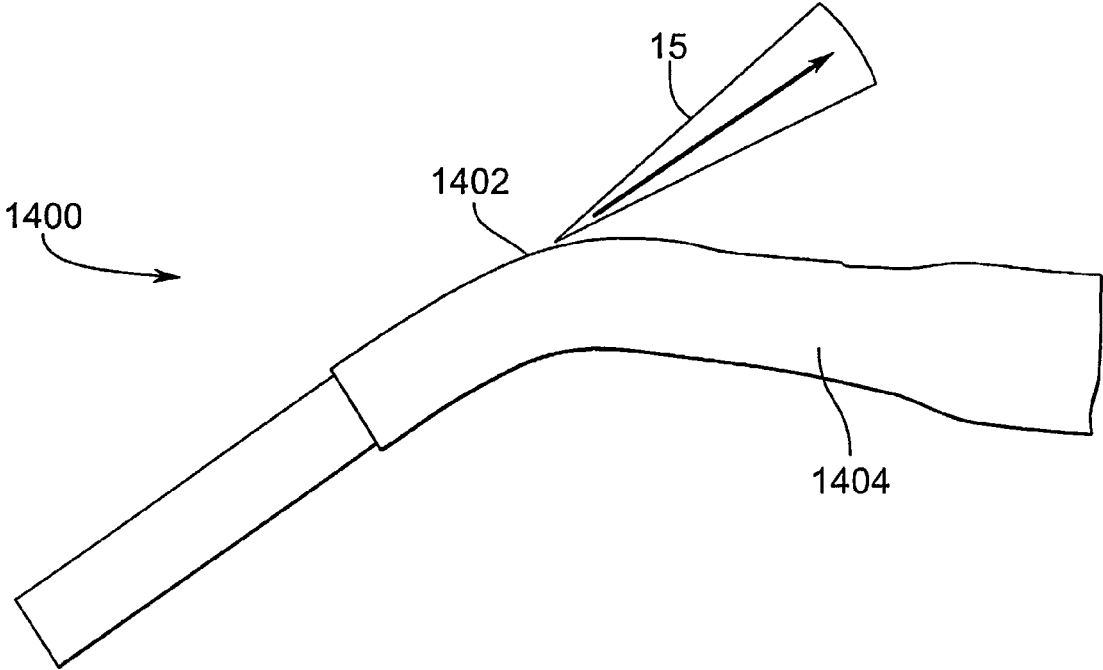

FIG. 14

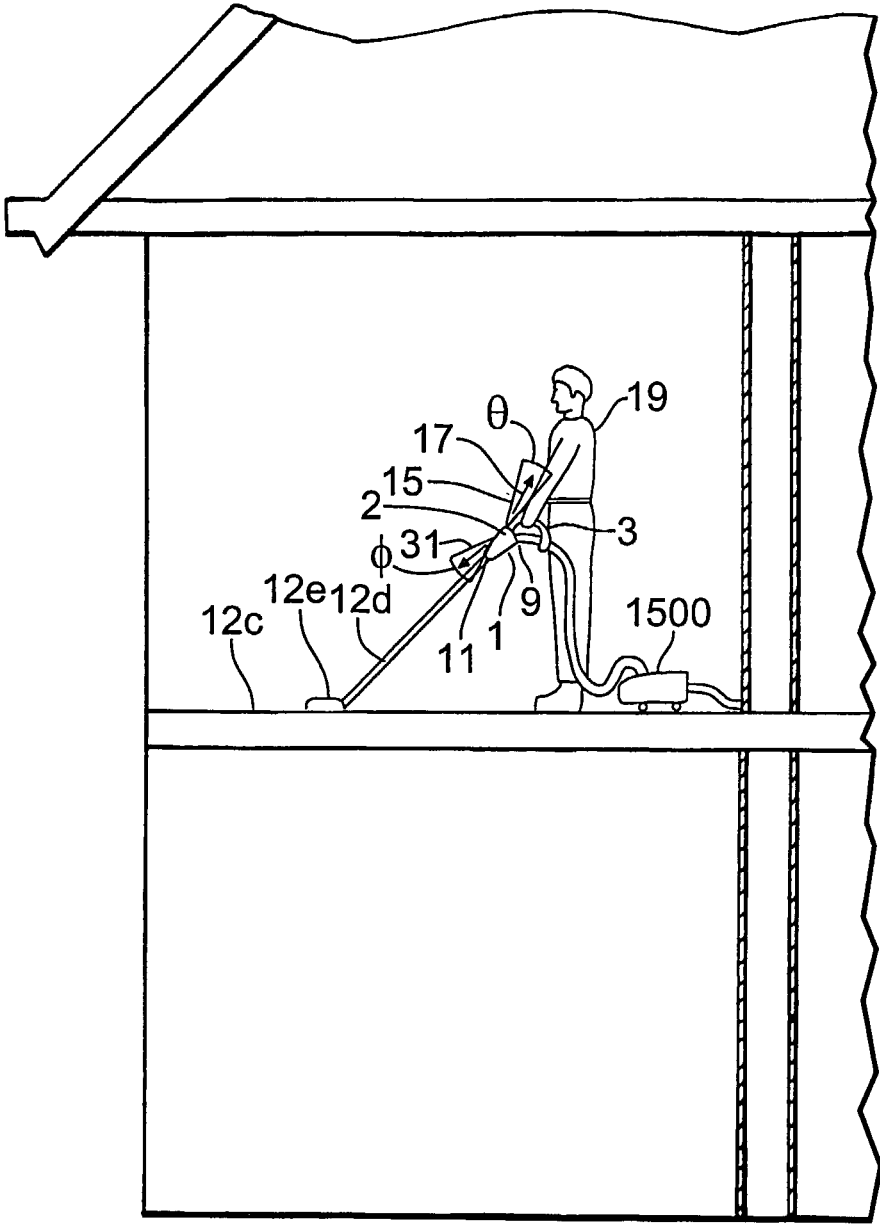

FIG. 15

1

## CLEANER HANDLE AND CLEANER HANDLE HOUSING SECTIONS

### CROSS-REFERENCE TO RELATED APPLICATIONS

This application claims priority from, and the benefit of, the filing date of U.S. Patent Application No. 60/610,557 filed 17 Sep. 2004 under title Cleaner Handle And Cleaner Handle Housing Sections. The contents of the above application is hereby incorporated by reference into the MODE(S) FOR CARRYING OUT THE INVENTION herein.

### TECHNICAL FIELD

The invention relates to cleaner handles, and to housing sections therefor.

### BACKGROUND ART

Cleaners include vacuum cleaners, floor cleaners, and the like. Vacuum cleaners include all types of vacuum cleaners, such as, for example, central vacuum cleaners, canister vacuum cleaners and upright vacuum cleaners.

Makers of cleaners have been adding features to their cleaners in order to remain competitive. For example, illuminated indicators have been used for many years to provide information about the status of the cleaner to an operator. The indicators may provide information such as whether or not the cleaner is ON. These indicators are helpful for all cleaners. They are particularly helpful in cleaners that have components remote from a handle that an operator of the cleaner grasps while vacuuming, such as in a central vacuum cleaner.

The indicators have been placed on the handle itself. Originally these indicators used incandescent bulbs that emitted from a top surface of the handle. More recently, the indicators use LED lamps emitting from a top surface of the handle.

Lights have also been used on powered attachments at floor level to illuminate in front of the attachment while cleaning. Also, microphones have been used to sense dust particles moving through a cleaner.

Improvements or alternatives to currently available features for cleaners are desirable.

### DISCLOSURE OF THE INVENTION

In a first aspect the invention provides a cleaner handle for use on a cleaner. The handle has a grasping section for manipulating the cleaner, an indicator housing, and at least one indicator within the indicator housing. The indicator has a limited viewing angle and a central axis. The central axis is directed over and across the grasping section such that the indicator is within the view of an operator holding the grasping section in an ordinary vacuuming position.

The cleaner may be a vacuum cleaner. The cleaner may be a central vacuum cleaner. The cleaner may be a canister vacuum cleaner. The cleaner may be an upright vacuum cleaner.

The indicator may be an LED lamp. The indicator may be an LCD display. The central axis of the indicator may be generally parallel with a cleaning axis of the handle, the cleaning axis being a line from the handle to a location currently being cleaned by the cleaner. The central axis of the indicator may be directed approximately 5 degrees vertically above a cleaning axis of the handle, the cleaning axis being a line from the handle to a location currently being cleaned by the cleaner.

2

The handle may also have an illuminator housing, a light within the illuminator housing, the light for illuminating with visible light an area that is being cleaned with the cleaner. A central beam axis of the light may be generally parallel with a cleaning axis of the handle, the cleaning axis being a line from the handle to a location currently being cleaned by the cleaner. A central beam axis of the light may be directed within approximately 5 degrees vertically of a cleaning axis of the handle, the cleaning axis being a line from the handle to a location currently being cleaned by the cleaner.

The handle may have a distal end for receiving particles from a location being cleaned. The indicator may be located between the distal end and the grasping section. The handle may have an indicator housing section that houses the indicator. The indicator housing section may have an aperture with the indicator viewable through the aperture. The aperture may be raised such that the indicator is viewable over a hand of an operator that is grasping the grasping section.

The handle may have a particle sensor for sensing particles flowing through the handle during operation of the cleaner. The particle sensor may have a microphone for sensing sound emitted when particles collide with a conduit in the handle as the particles flow through the cleaner. The conduit may be made from metal. The microphone may be held against the conduit by a spring mechanism. The spring mechanism may be a biased curved plastic strip.

The indicator may be within the view of the operator when the operator is viewing a location being cleaned by the cleaner.

In a further aspect the invention provides a cleaner handle for use on a cleaner. The handle includes a grasping section for manipulating the cleaner, an indicator housing, and at least one indicator within the indicator housing, the indicator having a limited viewing angle and a central axis. The central axis is directed over and across the grasping section such that the indicator is within the view of an operator holding the grasping section and viewing a location being cleaned by the cleaner.

The view of the operator includes a line to the location that is generally parallel to a cleaning axis of the handle, the cleaning axis being a line between the handle and the location being cleaned.

The central beam axis of the indicator may be directed at least 5 degrees vertically above a cleaning axis of the handle, the cleaning axis being a line from the handle to a location currently being cleaned by the cleaner.

The indicator beam angle may be approximately 20°. The light may be one or more LED lamps. The beam angle of each LED lamp may be approximately 12°.

In a still further aspect the invention provides a cleaner handle section for attachment to a housing of a cleaner handle having a grasping section for manipulating the cleaner. The cleaner handle section includes an indicator housing section, and at least one indicator within the indicator housing section, the indicator having a limited viewing angle and a central axis. The central axis is directed over and across the grasping section such that the indicator is within the view of an operator holding the grasping section and viewing a location being cleaned by the cleaner.

In another aspect the invention provides a cleaner handle for use on a cleaner. The handle includes a grasping section for manipulating the cleaner, an indicator housing, and at least one indicator within the indicator housing. The indicator has a lamp for emitting a visible beam of light from the indicator housing with a limited beam angle and a central beam axis. The central beam axis is directed over and across

the grasping section such that the beam is within the view of an operator holding the grasping section in an ordinary vacuuming position.

The indicator housing section may have an aperture and the beam of light may emit from the aperture. The aperture may be raised such that the indicator beam of light emits over a hand of an operator that is grasping the grasping section. The beam may be within the view of the operator when the operator is viewing a location being cleaned by the cleaner.

In yet another aspect the invention provides a cleaner handle for use on a cleaner. The handle includes a grasping section for manipulating the cleaner, an indicator housing, and at least one indicator within the indicator housing. The indicator has a lamp for emitting a visible beam of light from the indicator housing with a limited beam angle and a central beam axis. The central beam axis is directed over and across the grasping section such that the beam is within the view of an operator holding the grasping section and viewing a location being cleaned by the cleaner.

In still another aspect the invention provides a cleaner handle section for attachment to a housing of a cleaner handle having a grasping section for manipulating the cleaner. The cleaner handle section includes an indicator housing section and at least one indicator within the indicator housing section, the indicator including a lamp for emitting a visible beam of light from the indicator housing with a limited beam angle and a central beam axis. The central beam axis is directed over and across the grasping section such that the beam is within the view of an operator holding the grasping section and viewing a location being cleaned by the cleaner.

Other aspects of the invention are evident from the Mode(s) For Carrying Out The Invention herein.

#### BRIEF DESCRIPTION OF THE DRAWINGS

For a better understanding of the present invention and to show more clearly how it may be carried into effect, reference will now be made, by way of example, to the accompanying drawings which show the preferred embodiment of the present invention and in which:

FIG. 1 is a side view of a handle in accordance with a preferred embodiment of the present invention,

FIG. 2 is a partial cross-section of a building containing a central vacuum cleaner utilizing the handle of FIG. 1;

FIG. 3 is a top view of the handle of FIG. 1;

FIG. 4 is a perspective view from above, to the rear and to one side of a portion of the handle of FIG. 1;

FIG. 5 is a perspective view from above, to the front, and to one side of the handle of FIG. 1;

FIG. 6 is a cross-section of a portion of the handle of FIG. 1 along the line A-A' of FIG. 3;

FIGS. 7-12 are side views of alternate embodiments of a handle in accordance with an embodiment of the present invention;

FIG. 13 is a perspective view of an upright vacuum cleaner utilizing a handle in accordance with an embodiment of the present invention;

FIG. 14 is a side view of an alternate embodiment of a handle in accordance with an embodiment of the present invention, and

FIG. 15 is a partial cross-section of a building containing a central vacuum cleaner utilizing the handle of FIG. 1.

#### MODE(S) FOR CARRYING OUT THE INVENTION

Referring to FIGS. 1 through 7, a cleaner handle 1 has a housing 2 with a grasping section 3, a control input 5 (a

two-way button switch is shown for the control input 5 in the FIGS.), and a hose receiver 7. The handle 1 also has a generally tubular conduit 9. The hose receiver 7 receives a vacuum hose 10 and provides fluid connection from the hose 10 to the conduit 9. The conduit 9 has a distal end 11a that is open to draw in particles through the conduit 9 for transfer to the hose 10. The vacuum hose 10 may be connected to a wall outlet 12a in the case of a central vacuum cleaning system 12b, or to a vacuum canister in the case of a canister vacuum (see for example FIG. 15). The grasping section 3 is connected to the conduit 9 to allow a user of the vacuum cleaner to grasp the grasping section 3 and manipulate the conduit 9 to vacuum clean a desired location, such as a floor 12c.

The conduit 9 is typically separate from the housing 2 and made of metal, such as chromed steel, and, for this reason is sometimes referred to as a "metal wand"; however, the conduit 9 could be made from plastic or another rigid material. Also, the conduit 9 may be integrated with the housing 2. Where the conduit 9 is separate from the remainder of the housing 2, the housing 2 must have a conduit holder 11b. In the handle 1, the conduit holder 11b is provided in two conduit holder portions 11c, 10d. The distal end 11a of the conduit 9 may receive attachments, such as conduit extensions 12d for cleaning locations further away from the handle, carpet sweepers 12e, brushes (powered and unpowered), crevices tools, and the like, not shown.

Between the grasping section 3 and the distal end 11a, the handle 1 has indicators 13 (shown individually as 13a, 13b, 13c, 13d in the FIGS.). Each indicator 13 is a lamp for emitting a visible beam of light 15 from the housing 2. The beam of light 15 has a limited bandwidth  $\theta$  and a central beam axis 17. Each beam of light 15 is directed towards an operator 19 when the operator 19 is in an ordinary vacuuming position, such as cleaning a floor when standing as shown in FIG. 2. Each beam 15 is in a view 250 of the operator 19 when the operator 19 is using the handle 1 in an ordinary vacuuming position. The beam 15 is in the view 250 of the operator 19 when the operator 19 is using the handle and viewing a location 12c being cleaned. For clarity, in the FIGS. only a beam of light 15 for a single indicator 13 is shown. It is understood that each indicator will have its own beam of light 15.

Preferably, each indicator 13 is an LED lamp. LED lamps have many benefits, any one of which may be desirable to a designer creating a handle in accordance with the principles described herein. LED lamps are relatively inexpensive, small, efficient (drawing little energy when compared to light output), output less heat than most other light sources, and are long lasting. In addition, they are available in many colours, including multi-coloured LED lamps, and can be mounted on a printed circuit board.

In the preferred embodiment there are four indicators 13a, 13b, 13c, 13d. Indicators 13a, 13b, 13d are green, while indicator 13c is red. Illumination of indicator 13c indicates that particles are flowing through the conduit 9. The manner in which this is sensed in the preferred embodiment will be discussed later below. If no particles are sensed flowing through the conduit 9 then indicator 13c is off and indicator 13a is illuminated. When the cleaner is on, indicator 13b is illuminated, and if a power brush is attached and turned on then indicator 13d is illuminated. Other colours may be used, such as, for example, readily available amber, yellow or blue LEDs. Greater or fewer indicators 13 may be used. The indicators 13 may be multi-coloured to indicate a plurality of conditions with a single indicator. Also, the indicators 13 may illuminate according to different timing patterns to indicate different conditions.

As a further example, the indicators **13** may be an LCD display of compatible size. An LCD display has many of the advantages of LEDs including relatively low cost and low power draw. An LCD display can be driven to display icons for the indication of different conditions such as those discussed above. The LCD display may be backlit such that the LCD display is an indicator emitting a visible beam of light **15** from the face of the LCD display with a limited beam angle  $\Theta$  and a central axis **17**. If the LCD display is not backlit, then the icons may simply have contrasting shades that are viewable when the LCD is lit by ambient light. In this case, the direction of the LCD display from a central point of the screen (the "central axis") is equivalent to the central beam axis **17**. Similarly, the viewing angle of the LCD display will be equivalent to the angle  $\Theta$  and the area within the viewing angle will be equivalent to the beam of light **15**.

The central beam axes **17** are directed from between the distal end **11a** and the grasping section **3** in the view of an operator **19** using the handle **1** in an ordinary vacuuming position. The central beam axes **17** are directed over and across the grasping section **3** from between the distal end **11a** and the grasping section **3**.

The indicators **13** are in an indicator housing section **21** of the housing **2**. The indicator housing section has an aperture **23** through which the beams of light **15** emit from the housing **2**. The aperture **23** in the indicator housing section **21** in the handle **1** is raised above the grasping section **3** in order to allow the central beam axes **17** to pass over and across the grasping section **3** without being blocked by the hand of the operator **19**, or other components such as, for example, the switch **5**.

The handle **1** also has a light **25** for emitting visible light for illuminating a location **12c** to be cleaned. The light **25** is one or more LED lamps **25** (one lamp **25** is shown in the FIGS.). The LED lamp **25** outputs greater light intensity than the indicator **13**, as the lamp **25** is intended to illuminate the location **12c**. The intensity of the light **25** may be selected to illuminate an area **12c** that is close to the handle, for example for use when the handle **1** is used without extensions **12d**. Alternatively, the intensity may be selected to illuminate both a close location **12c**, and a location that is further from the handle **1** when the handle **1** is used with one or more extensions **12d**. The light preferably emits white light; however, other wavelengths could be used as desired by a designer of the handle, such as red, green, amber, yellow or blue.

The light **25** is in an illumination housing section **27** of the housing **2** between the grasping section **3** and the distal end **11a**. The illumination housing section **27** has an aperture **29** through which a beam of light **31** shines toward a location **12c** to be cleaned. In the handle **1**, the illumination housing section **27** is closer to the distal end **11a** of the handle **1**, while the indicator housing section **21** is closer to the grasping section **3**; so that, the illumination housing section **27** and the indicator housing section **21** do not block their respective beams of light **15**, **31**. In the handle **1**, the illumination housing section **27** and the indicator housing section **21** are integrated as a single illumination indicator housing section **33**.

The beam of light **31** has a limited beam angle  $\Phi$  and a central beam axis **34**. The central beam axis **34** is directed towards the location to be cleaned **12c**. The beam angle  $\Phi$  is selected to illuminate a desired amount of the area to be cleaned at a given distance. If the intensity of the light is selected for close work only, then the beam angle  $\Phi$  could be broader than for illumination of an area **12c** that is further away. Suitable LED lamps include Lite-on, Inc. of Milpitas, Calif. part no. LTL33BCWK5AT or Kingbrite of City of Industry, Calif. part no. W7524PWC4H. The Kingbrite lamp

has a beam angle  $\Phi$  of approximately 12 degrees and an intensity of approximately 7500 mcd. It is to be recognized that additional optics could be provided to allow the beam angle  $\Phi$  to be altered when in use.

Referring in particular to FIG. **6**, the indicators **13** (**13a** and **13c** are shown in the FIG.) are mounted on a printed circuit board **35**, while the light **25** is mounted on a printed circuit board **37**. Another printed circuit board, not shown is mounted within the housing **2** with a control circuit, including a microprocessor for controlling operation of the handle **1**. For clarity, wiring connections between the various boards **35**, **37**, the control circuit board and other components within the handle **1**, such as hose receiver **7**, are not shown. In a wired control application, low voltage wires extend from the handle **1** through the hose receiver **7** and hose **10** to a central vacuum suction unit **43** (FIG. **2**), or to a canister vacuum (see for example FIG. **15**) or to another vacuum cleaner suction unit, such as a suction motor of an upright vacuum (see for example FIG. **13**). Wireless control is also possible, for example, as described in a co-pending United States patent application of J. Vern Cunningham entitled Central Vacuum Cleaning System Control Subsystems filed 9 Sep. 2004, application number not yet known, the content of which is hereby incorporated by reference into the detailed description hereof.

It has been found that it is acceptable for the beam of light **15** central axis **17** to emit substantially parallel to a cleaning axis **44** of the handle **1**, provided that the beam angle  $\theta$  is broad enough to remain in the view of an operator in ordinary cleaning positions. The view of the operator typically includes a line generally parallel to the cleaning axis **44** to a location being cleaned. The angle between the view **250** of the operator to the location being cleaned and the cleaning axis **44** will vary as the operator moves about during cleaning. In the preferred embodiment the central axis **17** of the beam of light **15** is angled vertically away from the cleaning axis **44** at an angle of approximately 5 degrees. Suitable LED lamps include Kingbrite of City of Industry, Calif. part no. KM2520A01SGC (green) and KM2520A01SRC003 (red) with a beam angle of approximately 20 degrees and an intensity of approximately 100 mcd in the configuration of the handle **1**. Again, the particular angle between the cleaning axis **44** and the central axis **17**, and the particular beam angle  $\theta$ , chosen will depend on the particular configuration for the handle **1**. In addition to allowing clearance of other components of the handle **1** (such as switch **5**) and a hand of an operator **19**, a central axis **17** with a slight upward angle from the cleaning axis **44** may align the central axis more closely with an eye of a typical operator **19** using the handle **1** in an ordinary cleaning position.

The cleaning axis **44** is a line from the distal end **11a** to a location **12c** that is currently being cleaned. The cleaning axis **44** is typically perpendicular to the distal end **11a** of the handle **1**. Typically, the distal end **11a** has a straight portion **45** for receiving attachments, such as those described previously. This straight portion typically defines the cleaning axis **44** of the handle **1**. Similarly, it has been found that acceptable for the beam of light **31** central axis **34** to emit substantially parallel to the cleaning axis **44**. In the preferred embodiment the central axis **34** is vertically angled toward the cleaning axis **44** at an angle of approximately 5 degrees.

Accordingly, in the handle **1** the indicators **13** are surface mounted to the printed circuit board **35**. The printed circuit board **35** is mounted generally perpendicular to the cleaning axis **44**, offset by approximately 5 degrees vertically in the preferred embodiment. Similarly, in the handle **1** the lamps **25** are surface mounted to the printed circuit board **37**. The printed circuit board **37** is mounted generally perpendicular

to the cleaning axis **44**, offset by approximately 5 degrees vertically in the preferred embodiment. Thus, the indicators **13** and the lamps **25** are mounted such that their central axes **17**, **34** are substantially parallel with one another; although, the respective beams of light **15**, **31** emit in opposite directions. The indicators **13** and the lamps **25** are generally in line with one another, save and except for design limitations, such as, for example, a required distance between respective indicators **13** to allow them to be physically distinguished.

The aperture **23** is covered by a protective transparent lens **47** to prevent damage to the indicators **13** and other components of the handle **1**. The aperture **23** is curved inwardly for aesthetic appeal and also to provide a visual indication of the location of the switch **5**. Similarly, the aperture **29** is covered by a protective lens **49**. The lens **49** can be transparent, or it may be translucent to diffuse the beam of light **31** and to hide internal components. The lens **49** may have other optical qualities dependent on the characteristics desired for a given application. The lens **49** is curved outwardly to provide a smooth external surface for the illumination housing section **27**.

The housing **2** also contains a microphone **100** that rests against a section **102** of the conduit **9** that is impacted by particles in the conduit **9** when in use. Typically the section **102** is an outside of a bend in the conduit **9** that forces the particles against the conduit **9**. Preferably the conduit **9** made of a material that transmits sound well, such as the chromed metal typically used in "metal wands". The microphone **100** is connected to the control circuit and transmits sounds caused by particles colliding with the conduit **9** to the control circuit for use in controlling the handle **1** and, possibly, the cleaning system of which it is a part. The microphone **100** acts as a particle sensor. In the preferred embodiment, one of the indicators **13c** illuminates when particles are sensed, and indicator **13a** illuminates when particles are not sensed. This provides a visual indication to the operator **19** of particles at the location **12c** being cleaned. Among other things, the operator **19** may use this information to go back over that location until no further particles are sensed, or as a prompt to consider why particles are being found in a particular location.

The microphone **100** is held against the conduit **9** using a spring mechanism **104**. In the handle **1**, the spring mechanism **104** is a plastic strip **106** that is curved and biased toward the conduit **9** up against the microphone **100**. The microphone **100** is held laterally by four fixed plastic strips **108a**, **108b**, **108c** (the fourth strip is not shown in FIG. 6) that allow the microphone **100** to slide upwardly against the spring mechanism **104**, or for removal for replacement or repair. The strip **106** extends downwardly from the strip **108a**. In the preferred embodiment the microphone **100** is in the form of a cylinder enclosed in rubber. The rubber assists in dampening vibrations at the microphone **100**. Wires, not shown, extend from the top **109** of the microphone **100**. The spring mechanism **104** is located to avoid the wires on the top **109** of the microphone **100**. There are many other configurations of microphone that may be used in the handle **1**, with or without the particular spring mechanism described herein. Other spring mechanisms could be used to bias the microphone **100** against the conduit **9**.

The indicator housing section **21** and the illuminator housing section **27** can be integrated with one another, as in the indicator illuminator housing section **33**. The indicator illuminator housing section **33** may be integrated with the remainder of the housing **2**. In this case, the housing **2** would

typically be provided as two halves along the cross-section line shown in FIG. 6. This is commonly referred to as a "clamshell" configuration.

Alternatively, the illuminator indicator housing section **33** could be provided as a separate unit **109** that is mounted to the remainder of the housing **2**. This is particularly advantageous for retrofit applications to an existing handle. This is the configuration shown in the FIGS. for handle **1**. The illuminator indicator housing section **33** fits into an existing control opening **110** in the housing **2**, covering the opening **110**. The section **33** has a flange, not evident in FIG. 6, that fit beneath an outer shell **112** of housing **2** and rests on ribs **114** extending from the interior of the shell **112**. For assembly, the unit **109** is placed in one "clamshell" half **116** and another clamshell half, not shown in FIG. 6, is mounted over the unit **109** to the clamshell half **116**. This fastens the unit **109** to the remainder of the housing **2**, and provides a simple way to removably retain the illuminator indicator housing section **33** against the remainder of the housing **2**. The microphone **100** and related components, control circuit and wiring are mounted in the unit **109** and clamshell half **116** before the second clamshell half is assembled. The clamshell halves are generally mirrors of one another, and the unit **109** is generally symmetrical about the cross-section line of FIG. 6.

For ease of manufacture and assembly, the unit **109** is made from two pieces of moulded plastic: a top portion **118** and a bottom portion **120**. The other components of the unit **109**, including, for example, switch **5**, boards **35**, **37** and lenses **47**, **49** fit into or between the top portion **118** and bottom portion **120**. The top portion **118** is held to the shell **112** by the bottom portion **120** at raised flange **122** of bottom portion **120** in the front and at lowered flange **124** of top portion **118** in the rear. The unit **109** is assembled prior to insertion in the clamshell half **116**.

Alternatively, the unit **109** could be snap fitted into the opening **110** after the clamshell halves are mated. Any necessary wiring would need to be connected before the clamshell halves are mated, or be brought out of the opening for connection to the unit **109**. The unit could be retained in the opening using, for example, resilient tabs. Alternatively, the unit **109** can be mounted is screws or other such fastening means.

Referring to FIGS. 7-14, cleaner handles can come in many different configurations. Examples of embodiments utilizing various principles as described herein are shown. It is to be understood that these are examples embodiments only and are not intended as a complete review of all possible embodiments. It will be evident to those skilled in the art based upon the principles described herein that many more embodiments are possible. In these alternate embodiments like reference numerals will be used for like components and the description will not be repeated. The components of the handle **1** can be used in the other embodiments as desired for the particular embodiment.

Referring to FIG. 7, a hose handle **700** has one or more indicators that each emit a beam of light **15** to an operator. The handle **700** has a more rounded design than that of the handle **1**. The handle **100** does not have a light for illumination of a location to be cleaned.

Referring to FIG. 8, hose handle **800** is similar to hose handle **700**, except that the handle **800** has a light **25** that emits a beam **31** to a location to be cleaned.

Referring to FIG. 9, a hose handle **900** has an open handle configuration. The handle **900** has one or more indicators that each emit a beam of light **15** to an operator, and a light **25** that emits a beam **31** to a location to be cleaned.

Referring to FIG. 10, a hose handle 1000 has a less-rounded closed configuration. The handle 1000 also has a light that emits a beam of light 31 to a location to be cleaned.

Referring to FIG. 11, a hose handle 1100 is similar to handle 1000, except that the handle 1100 also has indicators that emit beams of light 15 to an operator.

Referring to FIG. 12, a hose handle 1200 has a pistol configuration. The handle 1200 has indicators that emit a beam of light 15 to an operator, and a beam of light 31 to a location to be cleaned.

Referring to FIG. 13, an upright vacuum cleaner 1300 has a handle 1302 that has indicators that emit a beam of light 15 to an operator, and a beam of light 31 to a location to be cleaned.

Referring to FIG. 14, although it is preferable to have a raised housing section 21, a handle 1400 has an indicator that is placed at an angle to surface 1402 of handle housing 1404. The angle is selected to direct a beam of light 15 from the indicator such that the beam of light falls within the view of the operator when using the handle in an ordinary vacuuming position. The orientation of the beam of light may be parallel to a cleaning axis of the handle 1400, or it may be oriented upwardly to avoid obstructions, such as a hand of the operator on the handle.

The beam of light 15 could be emitted perpendicular to the surface of a handle, provided that the surface was oriented to allow beam of light 15 to be in view of the operator when using the handle in an ordinary vacuuming position.

Referring to FIG. 15, a handle 1 is used in association with a canister vacuum cleaner unit 1500.

Clearly, many different embodiments based on the principles described herein are possible. Beams of light can be emitted from a lamp at a cleaner handle to illuminate a location to be cleaned. Beams of light can be directed from an indicator of a cleaner handle to an operator and be viewable when the handle is used in an ordinary cleaning position. The illumination lamp and the indicator can be provided separately, or provided on the same handle. The beams of light can have a limited viewing angle.

It will be understood by those skilled in the art that this description is made with reference to the preferred embodiment and that it is possible to make other embodiments employing the principles of the invention which fall within its spirit and scope as defined by the following claims.

We claim:

1. A cleaner handle for use on a cleaner, the handle comprising:

- a) a grasping section for manipulating the cleaner,
- b) an indicator housing,
- c) at least one indicator within the indicator housing, the at least one indicator having a limited viewing angle and a central axis,

wherein the central axis is directed over and across the grasping section, wherein the central axis of the indicator is generally parallel with a cleaning axis of the handle, and wherein the handle comprises a handle distal end where particles are to be drawn into the handle, and a straight portion at the handle distal end having a longitudinal axis that is the cleaning axis.

2. The handle of claim 1, wherein the cleaner is a vacuum cleaner.

3. The handle of claim 1, wherein the cleaner is a central vacuum cleaner.

4. The handle of claim 1, wherein the cleaner is a canister vacuum cleaner.

5. The handle of claim 1, wherein the cleaner is an upright vacuum cleaner.

6. The handle of claim 1, wherein the indicator is an LED lamp.

7. The handle of claim 1, wherein the indicator is an LCD display.

8. The handle of claim 1, further comprising:

- a) an illuminator housing, and
  - b) a light within the illuminator housing, the light for illuminating with visible light an area that is being cleaned with the cleaner,
- wherein a central beam axis of the light is generally parallel with the cleaning axis of the handle.

9. The handle of claim 8 wherein the light is one or more LED lamps.

10. The handle of claim 9 wherein each LED lamp has a beam angle of approximately 12°.

11. The handle of claim 12, wherein the indicator housing section comprises: an aperture, and the indicator is viewable through the aperture.

12. The handle of claim 11, wherein the aperture is raised such that the indicator is viewable over a hand of an operator that is grasping the grasping section.

13. The handle of claim 12, further comprising: a particle sensor for sensing particles flowing through the handle during operation of the cleaner.

14. The handle of claim 13, wherein the particle sensor comprises: a microphone for sensing sound emitted when particles collide with a conduit in the handle as the particles flow through the cleaner.

15. The handle of claim 14, wherein the conduit is metal.

16. The handle of claim 14, wherein the microphone is held against the conduit by a spring mechanism.

17. The handle of claim 16, wherein the spring mechanism is a biased curved plastic strip.

18. The handle of claim 1 wherein the indicator viewing angle is approximately 20°.

19. A cleaner handle for use on a cleaner, the handle comprising:

- a) a grasping section for manipulating the cleaner,
- b) an indicator housing,
- c) at least one indicator within the indicator housing, the at least one indicator having a limited viewing angle and a central axis,

wherein the central axis is directed over and across the grasping section, wherein the central axis of the indicator is directed approximately 5 degrees vertically above a cleaning axis of the handle, wherein the handle comprises a handle distal end where particles are to be drawn into the handle, and a straight portion at the handle distal end having a longitudinal axis that is the cleaning axis.

20. The handle of claim 19, further comprising:

- a) an illuminator housing, and
  - b) a light within the illuminator housing, the light for illuminating with visible light an area that is being cleaned with the cleaner,
- wherein a central beam axis of the light is directed within approximately 5 degrees vertically of the cleaning axis of the handle.

21. A cleaner handle for use on a cleaner, the handle comprising:

- a) a grasping section for manipulating the cleaner,
- b) an indicator housing,
- c) at least one indicator within the indicator housing, the at least one indicator having a limited viewing angle and a central axis,

wherein the central axis is directed over and across the grasping section, wherein the central axis of the indica-

11

tor is directed at least 5 degrees vertically above a cleaning axis of the handle, and wherein the handle comprises a handle distal end where particles are to be drawn into the handle, and a straight portion at the handle distal end having a longitudinal axis that is the cleaning axis.

22. The handle of claim 21, wherein the cleaner is a vacuum cleaner.

23. The handle of claim 21, wherein the cleaner is a central vacuum cleaner.

24. The handle of claim 21, wherein the cleaner is a canister vacuum cleaner.

25. The handle of claim 21, wherein the cleaner is an upright vacuum cleaner.

26. The handle of claim 21, wherein the indicator is an LED lamp.

27. The handle of claim 21, wherein the indicator is an LCD display.

28. The handle of claim 21, further comprising:

- a) an illuminator housing, and
- b) a light within the illuminator housing, the light for illuminating with visible light an area that is being cleaned with the cleaner,

wherein a central beam axis of the light is generally parallel with the cleaning axis of the handle.

29. The handle of claim 21, wherein the indicator housing section comprises: an aperture, and the indicator is viewable through the aperture.

30. The handle of claim 29, wherein the aperture is raised such that the indicator is viewable over a hand of an operator that is grasping the grasping section.

31. A cleaner handle for use on a cleaner, the handle comprising:

- a) a grasping section for manipulating the cleaner,
- b) an indicator housing section,
- c) at least one indicator within the indicator housing section, the at least one indicator including a lamp for emitting a visible beam of light from the indicator housing with a limited beam angle and a central beam axis,

wherein the central beam axis is directed over and across the grasping section, wherein the central beam axis of the indicator is generally parallel with a cleaning axis of the handle, and wherein the handle comprises a handle

12

distal end where particles are to be drawn into the handle, and a straight portion at the handle distal end having a longitudinal axis that is the cleaning axis.

32. The handle of claim 31, wherein the indicator housing section comprises: an aperture, and the beam of light emits from the aperture.

33. The handle of claim 32, wherein the aperture is raised such that the indicator beam of light emits over a hand of an operator that is grasping the grasping section.

34. A cleaner handle for use on a cleaner, the handle comprising:

- a) a grasping section for manipulating the cleaner,
- b) an indicator housing section,
- c) at least one indicator within the indicator housing section, the at least one indicator including a lamp for emitting a visible beam of light from the indicator housing with a limited beam angle and a central beam axis,

wherein the central beam axis is directed over and across the grasping section, wherein the central beam axis of the indicator is directed approximately 5 degrees vertically above a cleaning axis of the handle, and wherein the handle comprises a handle distal end where particles are to be drawn into the handle, and a straight portion at the handle distal end having a longitudinal axis that is the cleaning axis.

35. A cleaner handle for use on a cleaner, the handle comprising:

- a) a grasping section for manipulating the cleaner,
- b) an indicator housing section,
- c) at least one indicator within the indicator housing section, the at least one indicator including a lamp for emitting a visible beam of light from the indicator housing with a limited beam angle and a central beam axis,

wherein the central beam axis is directed over and across the grasping section, wherein the central beam axis of the indicator is directed at least 5 degrees vertically above a cleaning axis of the handle, and wherein the handle comprises a handle distal end where particles are to be drawn into the handle, and a straight portion at the handle distal end having a longitudinal axis that is the cleaning axis.

\* \* \* \* \*