



US008096014B2

(12) **United States Patent**
Cunningham et al.

(10) **Patent No.:** **US 8,096,014 B2**
(45) **Date of Patent:** **Jan. 17, 2012**

(54) **CENTRAL VACUUM CLEANER CONTROL, UNIT AND SYSTEM WITH CONTAMINANT SENSOR**

(75) Inventors: **J. Vern Cunningham**, Aurora (CA);
Allen D. Muirhead, Aurora (CA)

(73) Assignee: **Cube Investments Limited**, Aurora (CA)

(*) Notice: Subject to any disclaimer, the term of this patent is extended or adjusted under 35 U.S.C. 154(b) by 25 days.

(21) Appl. No.: **12/659,333**

(22) Filed: **Mar. 4, 2010**

(65) **Prior Publication Data**

US 2010/0162513 A1 Jul. 1, 2010

Related U.S. Application Data

(63) Continuation of application No. 11/245,218, filed on Oct. 7, 2005, now Pat. No. 7,690,075.

(51) **Int. Cl.**
A47L 9/28 (2006.01)

(52) **U.S. Cl.** **15/301**; 15/313; 15/314; 15/315;
15/339; 15/410

(58) **Field of Classification Search** 15/301,
15/313-315, 319, 339, 410; *A47L* 5/38, 9/28
See application file for complete search history.

(56) **References Cited**

U.S. PATENT DOCUMENTS

1,601,531 A	9/1926	Jeannin
1,883,288 A	10/1932	Zubaty
3,088,484 A	5/1963	Marsh
3,357,039 A	12/1967	Hayward
3,382,524 A	5/1968	Sandstrom

3,477,689 A	11/1969	Berghoefer
3,483,503 A	12/1969	Pardiso
3,565,103 A	2/1971	Maselek
3,570,809 A	3/1971	Stuy
3,626,545 A	12/1971	Sparrow
3,628,769 A	12/1971	Lee
3,661,356 A	5/1972	Tucker
3,663,845 A	5/1972	Apstein
3,676,986 A	7/1972	Reiling
3,826,464 A	7/1974	Berghoefer
3,855,665 A	12/1974	Schwartz
3,965,526 A	6/1976	Doubleday
3,989,311 A	11/1976	Debrey
4,056,334 A	11/1977	Fortune
4,070,586 A	1/1978	Breslin
4,111,615 A	9/1978	Watanabe
4,114,557 A	9/1978	De Brey
4,175,892 A	11/1979	De Brey

(Continued)

FOREIGN PATENT DOCUMENTS

EP 0192469 8/1986

(Continued)

OTHER PUBLICATIONS

Central Vacuum Systems Owners Guide, M&S Systems.

(Continued)

Primary Examiner — David Redding

(57) **ABSTRACT**

A central vacuum cleaning system **3** has a central vacuum unit **17** with a motor **10**, a motor compartment **19**, and a vacuum chamber **25**. The system **3** also has a control circuit **1** for controlling power to the motor **10**, and one or more airborne contaminant sensors **15** for sensing contaminants within the system **3**. The sensors **15** may be located in pipes **31** motor compartment **19**, vacuum chamber **25** and hose handle **34**. Vacuum air may be drawn through aperture **37** in wall valve **38**.

25 Claims, 2 Drawing Sheets

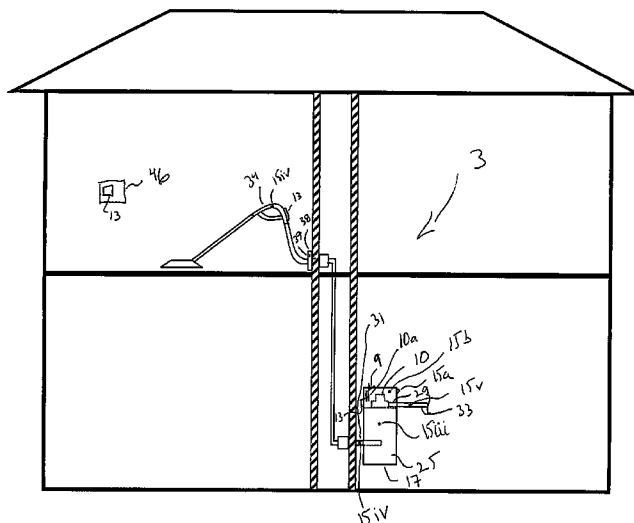

U.S. PATENT DOCUMENTS							
4,225,272	A	9/1980	Palmovist	5,568,374	A	10/1996	Lindeboom et al.
4,227,258	A	10/1980	Root et al.	5,572,767	A	11/1996	Ishikawa
4,246,675	A	1/1981	Costanzo	5,578,795	A	11/1996	Ward
4,300,262	A	11/1981	Rodowsky, Jr. et al.	5,606,767	A	3/1997	Crienjak et al.
4,336,427	A	6/1982	Lindsay	5,655,884	A	8/1997	Rose
4,368,348	A	1/1983	Eichelberger et al.	5,698,957	A	12/1997	Sowada
4,369,543	A	1/1983	Chen et al.	5,713,656	A	2/1998	Lin
4,370,776	A	2/1983	Kullik	5,722,110	A	3/1998	McIntyre et al.
4,443,906	A	4/1984	Tucker et al.	5,737,797	A	4/1998	Rittmueller et al.
4,473,923	A	10/1984	Neroni et al.	5,737,798	A	4/1998	Moren et al.
4,490,575	A	12/1984	Kutnyak	5,740,581	A	4/1998	Harrelson, II
4,494,270	A	1/1985	Ritzau et al.	5,740,582	A	4/1998	Harrelson, II
4,513,469	A	4/1985	Godfrey et al.	5,747,973	A	5/1998	Robitaille et al.
4,531,796	A	7/1985	Gansert et al.	5,753,989	A	5/1998	Syverson et al.
4,536,674	A	8/1985	Schmidt	5,813,085	A	9/1998	Fritz et al.
4,591,368	A	5/1986	MacDuff	5,815,883	A	10/1998	Stein et al.
4,611,365	A	9/1986	Komatsu et al.	5,815,884	A	10/1998	Imamura
4,654,924	A	4/1987	Getz et al.	5,816,685	A	10/1998	Hou
4,664,457	A	5/1987	Suchy	5,850,665	A	12/1998	Bousset
4,680,827	A	7/1987	Hummel	5,871,152	A	2/1999	Saney
4,683,515	A	7/1987	Beihoff et al.	D406,422	S	3/1999	Burchard et al.
4,688,596	A	8/1987	Liebmann	5,893,194	A	4/1999	Karmel
4,693,324	A	9/1987	Choiniere et al.	5,896,618	A	4/1999	Woo et al.
4,731,545	A	3/1988	Lerner et al.	5,917,428	A	6/1999	Discenzo et al.
4,757,574	A	7/1988	Sumerau	5,918,728	A	7/1999	Syverson
4,766,628	A	8/1988	Walker	5,924,163	A	7/1999	Burns, Jr.
4,791,700	A	12/1988	Bigley et al.	5,924,164	A	7/1999	Lindsay, Jr.
4,829,625	A	5/1989	Wang	5,926,908	A	7/1999	Lindsay, Jr.
4,829,626	A	5/1989	Harkonen et al.	5,926,909	A	7/1999	McGee
4,854,887	A	8/1989	Blandin	5,938,061	A	8/1999	Ward et al.
4,881,909	A	11/1989	Blackman	5,945,749	A	8/1999	Li
4,883,982	A	11/1989	Forbes et al.	5,983,443	A	11/1999	Redding
D315,043	S	2/1991	Hayden	5,987,697	A	11/1999	Song et al.
4,991,253	A	2/1991	Rechstiner	6,011,334	A	1/2000	Roland
5,033,151	A	7/1991	Kraft et al.	6,029,309	A	2/2000	Imamura
5,067,394	A	11/1991	Cavallero	6,033,082	A	3/2000	Lin
5,068,555	A	11/1991	Oberdorfer-Bogel	6,049,143	A	4/2000	Simpson et al.
5,107,565	A	4/1992	Chun	6,101,667	A	8/2000	Ishikawa
5,109,568	A	5/1992	Rohn et al.	D431,335	S	9/2000	Mehaffey et al.
5,111,841	A	5/1992	Houston et al.	6,169,258	B1	1/2001	Roney et al.
5,120,983	A	6/1992	Samaan	6,206,181	B1	3/2001	Syverson
5,125,125	A	6/1992	Barsacq	6,218,798	B1	4/2001	Price et al.
D333,023	S	2/1993	Herron, Jr.	6,232,696	B1	5/2001	Kim et al.
5,185,705	A	2/1993	Farrington	6,239,576	B1	5/2001	Breslin et al.
D334,447	S	3/1993	Rohn	6,244,427	B1	6/2001	Syverson
5,191,673	A	3/1993	Damizet	6,253,414	B1	7/2001	Bradd et al.
5,207,498	A	5/1993	Lawrence et al.	6,256,833	B1	7/2001	Steinberg
5,244,409	A	9/1993	Guss et al.	6,323,570	B1	11/2001	Nishimura et al.
5,255,409	A	10/1993	Fujiwara et al.	6,336,825	B1	1/2002	Seefried
5,263,502	A	11/1993	Dick	6,425,293	B1	7/2002	Woodroffe et al.
5,265,305	A	11/1993	Kraft et al.	6,459,056	B1	10/2002	Graham
5,274,578	A	12/1993	Noeth et al.	6,463,368	B1	10/2002	Feiten et al.
5,274,878	A	1/1994	Radabaugh et al.	6,546,814	B1	4/2003	Choe et al.
5,276,434	A	1/1994	Brooks et al.	6,628,019	B2	9/2003	Carroll
5,276,939	A	1/1994	Uenishi	6,658,325	B2	12/2003	Zweig
5,277,468	A	1/1994	Blatt et al.	6,685,491	B2	2/2004	Gergek
5,298,821	A	3/1994	Michel	6,690,804	B2	2/2004	Everett
5,301,385	A	4/1994	Abe et al.	D494,332	S	8/2004	Schroeter
5,311,639	A	5/1994	Boshler	D494,333	S	8/2004	Schroeter
5,343,590	A	9/1994	Radabaugh	6,779,228	B2	8/2004	Plomteux et al.
5,347,186	A	9/1994	Konotchick	6,791,205	B2	9/2004	Woodbridge
5,349,146	A	9/1994	Radabaugh	6,817,058	B1	11/2004	Harrelson, II
5,353,468	A	10/1994	Yap et al.	6,822,353	B2	11/2004	Koga et al.
5,363,534	A	11/1994	Dekker et al.	6,864,594	B2	3/2005	Seki
5,379,796	A	1/1995	Wang	6,900,565	B2	5/2005	Preston
5,391,064	A	2/1995	Lopez	6,975,043	B2	12/2005	Schumacher et al.
5,404,612	A	4/1995	Ishikawa	6,975,993	B1	12/2005	Keiller
5,409,398	A	4/1995	Chadbourne et al.	7,051,398	B2	5/2006	Smith et al.
5,448,827	A	9/1995	Ward	7,080,425	B2	7/2006	Smith et al.
D364,014	S	11/1995	Langeland et al.	7,114,216	B2	10/2006	Stephens et al.
5,479,676	A	1/1996	Martin et al.	7,122,921	B2	10/2006	Hall et al.
5,504,971	A	4/1996	McCormick	7,237,298	B2	7/2007	Reindle et al.
5,512,883	A	4/1996	Lane, Jr.	7,269,877	B2	9/2007	Tondra et al.
5,515,572	A	5/1996	Hoekstra et al.	7,328,479	B2	2/2008	Willenbring
5,525,842	A	6/1996	Leininger	7,331,083	B2	2/2008	Overvaag et al.
5,542,146	A	8/1996	Hoekstra et al.	7,342,372	B2	3/2008	Jonsson et al.
5,554,049	A	9/1996	Reynolds	7,363,679	B2	4/2008	Zimmerle et al.
5,560,076	A	10/1996	Leung	7,403,360	B2	7/2008	Cunningham et al.
				7,406,744	B2	8/2008	Bruneau

2002/0001190	A1	1/2002	Everett	JP	7-095944	11/1995
2002/0127916	A1	9/2002	Zhang	JP	7322980	12/1995
2002/0152576	A1	10/2002	Murray et al.	JP	8-033596	2/1996
2003/0044243	A1	3/2003	Tisdale	JP	8-117165	5/1996
2003/0140443	A1	7/2003	Najm	JP	8-065876	8/1996
2003/0196293	A1	10/2003	Ruff	JP	8-240329	9/1996
2003/0229421	A1	12/2003	Chmura et al.	JP	9-149871	10/1997
2004/0031506	A1	2/2004	Tsai	JP	10-094504	4/1998
2004/0049868	A1	3/2004	Ng	JP	2009-058919	9/1998
2004/0144633	A1	7/2004	Gordon et al.	JP	2000-116577	4/2000
2004/0150271	A1	8/2004	Koga et al.	JP	2001-137158	5/2001
2004/0172782	A1	9/2004	Smith et al.	JP	2002-078656	3/2002
2004/0177468	A1	9/2004	Smith et al.	JP	2002-320577	5/2002
2004/0231090	A1	11/2004	Kushida et al.	JP	2003-235767	8/2003
2004/0261211	A1	12/2004	Overvaag et al.	JP	2005-102465	4/2005
2005/0022329	A1	2/2005	Harman et al.	WO	9737423	10/1997
2005/0022337	A1	2/2005	Roney et al.	WO	9741631	11/1997
2005/0166351	A1	8/2005	Cunningham et al.	WO	98/35160	8/1998
2005/0236012	A1	10/2005	Josefsson et al.	WO	99/09875	3/1999
2005/0245194	A1	11/2005	Hayes et al.	WO	9956606	11/1999
2005/0254185	A1	11/2005	Cunningham	WO	0064323	11/2000
2007/0283521	A1	12/2007	Foster et al.	WO	W02005031169	A1 4/2005
2008/0066252	A1	3/2008	Herron, Jr.	WO	2007/017057	2/2007
2008/0222836	A1	9/2008	Cunningham			
2008/0301903	A1	12/2008	Cunningham et al.			

FOREIGN PATENT DOCUMENTS

EP	0347223	12/1989
EP	0552978	7/1993
EP	0499235	9/1995
EP	0711023	5/1996
EP	0773619	5/1997
GB	2281507	3/1995
GB	2288115	10/1995
JP	5-3058160	5/1978
JP	5-3128158	11/1978
JP	64-049526	2/1989
JP	2-152420	6/1990
JP	2-152419	12/1990
JP	4-017830	1/1992
JP	5-003839	1/1993
JP	5-317213	3/1993
JP	6-277167	10/1994

OTHER PUBLICATIONS

Heritage Central Vacuum, Crush Proof Hoses Non-Electric, <http://www.heritagevac.com/hosesnonelectric.html>, printed Sep. 21, 2005, pp. 4, Azusa, USA.

New Central Vacuum Breaks Home Automation Barrier, Business Wire dated Feb. 26, 2002.

The Eureka Company, Cordless, Rechargeable Vacuum Cleaner, Household Type, Owner's Guide, Model 570, 2000, pp. 12, Bloomington, USA.

The Eureka Company, Cordless, Rechargeable Vacuum Cleaner, Household Type, Owner's Guide, Model 96B, 2001, pp. 12, Bloomington, USA.

Ultimate Air Inc., The UltimateAir RecoupAerator 200DX Energy Recovery Ventilator, Owner's Manual and Installation Guide, Jan. 24, 2006, pp. i-iv, 1-41 Athens, USA.

Audioetccetera, Wireless Remote Control for Filtex Central Vacuum Systems, M&S Systems, date unknown, <http://www.audio-etcetera.com/prod.itml.icOid/135540>.

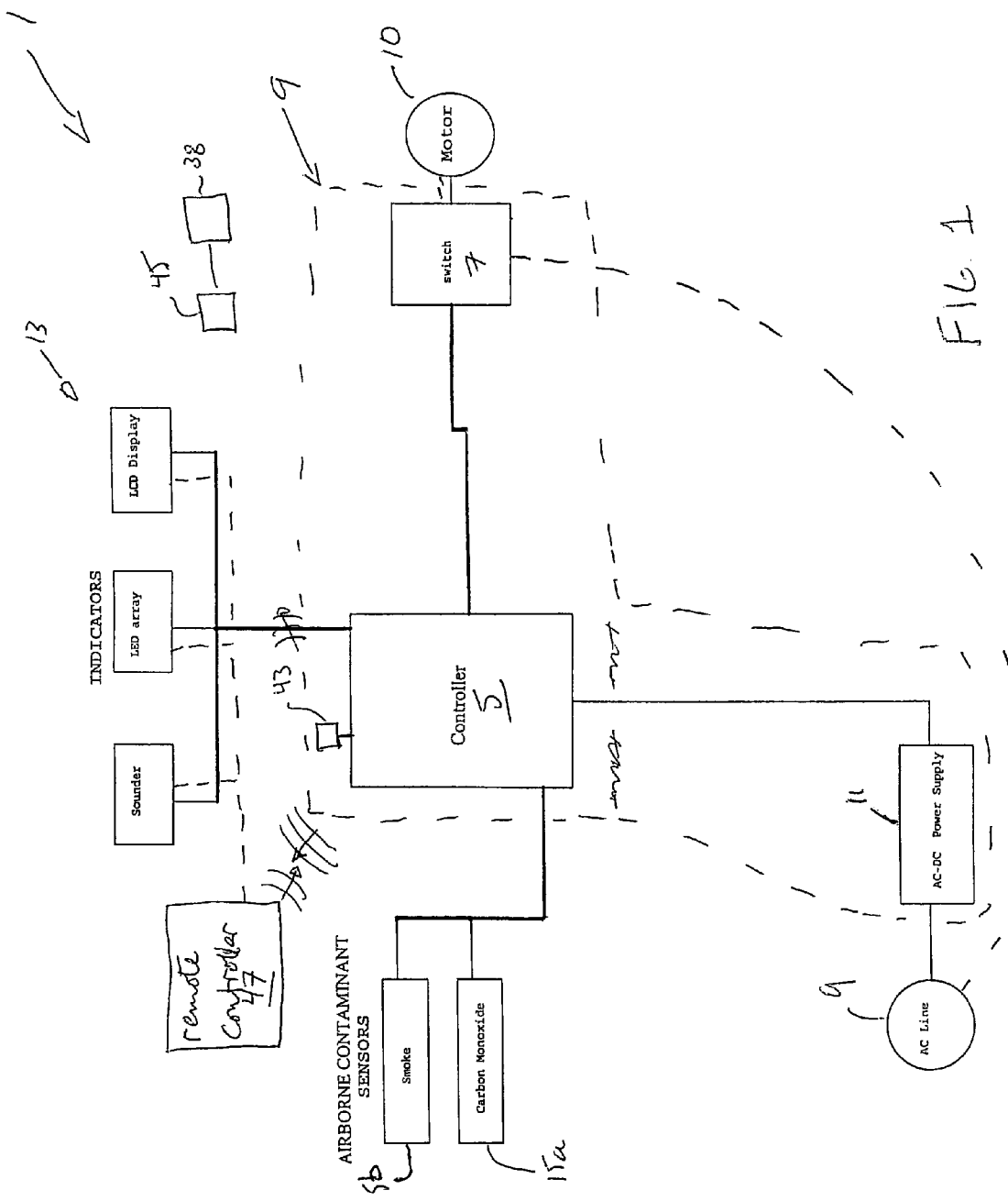

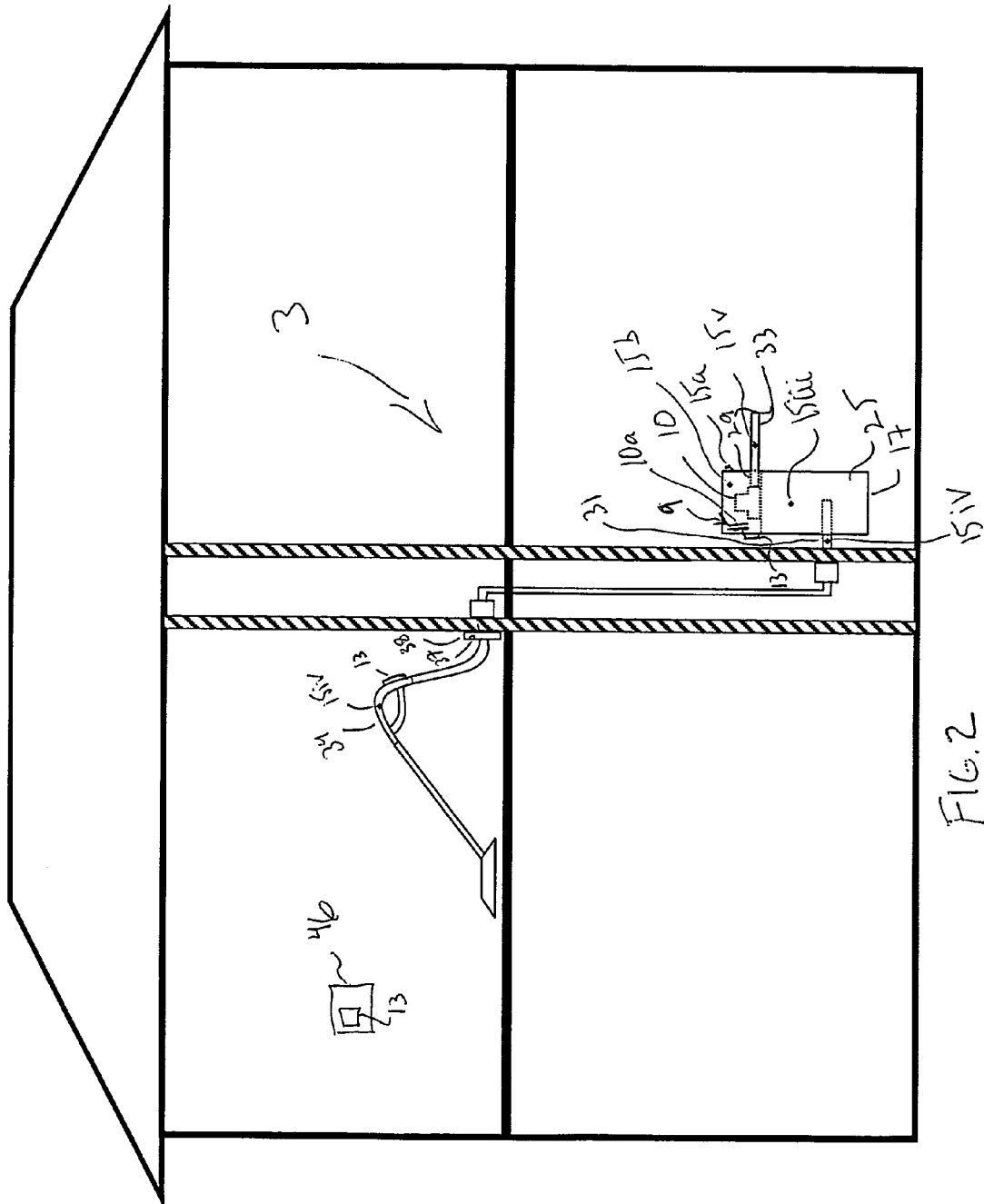

1

CENTRAL VACUUM CLEANER CONTROL, UNIT AND SYSTEM WITH CONTAMINANT SENSOR

CROSS-REFERENCE TO RELATED APPLICATION

This application is a continuation of allowed U.S. patent application Ser. No. 11/245,218, filed 7 Oct. 2007 under title CENTRAL VACUUM CLEANER CONTROL, UNIT AND SYSTEM WITH CONTAMINANT SENSOR, which is incorporated herein by reference.

FIELD OF THE INVENTION

The invention relates to central vacuum cleaning systems.

BACKGROUND OF THE INVENTION

Central vacuum cleaning systems were originally quite simple. One placed a powerful central vacuum source external to the main living space. The source was connected through interior walls to a long flexible hose that terminated in a handle and nozzle. When an operator desired to use the system, the operator went to the source and turned it on. The operator then went inside, picked up the handle and directed the nozzle to an area to be cleaned.

Although many elements of the basic system remain, many improvements have been made. Rigid pipes typically run inside interior walls to numerous wall valves spaced throughout a building. This allows an operator to utilize a smaller hose while covering an equivalent space. This is an advantage as the hose can be quite bulky and heavy.

Various communication systems have been developed. Some systems sense sound or pressure in the pipes to turn the vacuum source on or off, see for example U.S. Pat. No. 5,924,164 issued 20 Jul. 1999 to Edward W. Lindsay under title ACOUSTIC COMMUNICATOR FOR CENTRAL VACUUM CLEANERS. Other systems run low voltage wires between the source and the wall valve. The source can be turned on and off at a wall valve by a switch that may be activated by insertion or removal of the hose. The hose may also contain low voltage wires to allow the source to be controlled from a switch in the handle, see for example U.S. Pat. No. 5,343,590 issued 6 Sep. 1994 to Kurtis R. Radabaugh under title LOW VOLTAGE CENTRAL VACUUM CONTROL HANDLE WITH AN AIR FLOW SENSOR. The switch can be a simple toggle switch, or a more sophisticated capacitive switch.

The low voltage wires running along the pipes can be replaced by conductive tape or the like on the pipes, see for example U.S. Pat. No. 4,854,887 issued 8 Aug. 1989 to Jean-Claude Blandin under title PIPE SYSTEM FOR CENTRAL SUCTION CLEANING INSTALLATION. Separate low voltage conductors in the walls can be avoided altogether by home using mains power wires to transmit communication signals between the wall valve and the source, see for example U.S. Pat. No. 5,274,878 issued 4 Jan. 1994 to Kurtis R. Radabaugh et al under title REMOTE CONTROL SYSTEM FOR CENTRAL VACUUM SYSTEMS. A handheld radio frequency wireless transmitter can be used by an operator to turn the source on or off, see for example U.S. Pat. No. 3,626,545 issued 14 Dec. 1971 to Perry W. Sparrow under title CENTRAL VACUUM CLEANER WITH REMOTE CONTROL.

Line voltage can be brought adjacent the vacuum wall valves and connected to the handle through separate conduc-

2

tors, or integrated spiral wound conductors on the hose. Line voltage can then be brought from the handle to powered accessories, such as an electrically-powered beater bar, connected to the nozzle. Line voltage can be switched on and off to the powered accessory using the same switch in the handle that controls the source. Alternatively, the powered accessory may have its own power switch. It has been proposed to use the pipes of central vacuum cleaning systems to evacuate contaminants sensed by sensors in rooms to which the pipes are connected.

A control module mounted to the central vacuum unit is typically used to control the vacuum source. As central vacuum cleaning systems have become more and more sophisticated, so has the control module.

Improvements to, or additional or alternative features for, central vacuum cleaning systems are desirable.

SUMMARY OF THE INVENTION

In a first aspect the invention provides a central vacuum cleaning system control module for use in a central vacuum cleaning system having a central vacuum unit with a motor in a motor compartment. The module includes a control circuit controlling power to the motor. It also includes one or more airborne contaminant sensors in the control circuit for sensing airborne contaminants. The control module is dimensioned to fit within the motor compartment.

In a second aspect the invention provides a central vacuum unit for use in a central vacuum cleaning system. The unit includes a motor compartment, a vacuum chamber, a control circuit for controlling power to the motor, and one or more airborne contaminant sensors for sensing contaminants within the unit.

In a third aspect the invention provides a central vacuum cleaning system. The system includes a central vacuum unit having a motor, a motor compartment, a vacuum chamber, a control circuit for controlling power to the motor, and one or more airborne contaminant sensors for sensing airborne contaminants within the central vacuum cleaning system.

The at least one sensor may be located to sense airborne contaminants within vacuum air pipes of the system. The at least one sensor may be located in the suction vacuum air pipes of the system. The at least one sensor may be located in the exhaust vacuum air pipes of the system. The at least one sensor may be located to sense airborne contaminants within the motor compartment of the central vacuum unit.

The at least sensor may be mounted in a cooling air path of the motor after the motor. The control circuit may also include a control module that controls power to the motor. The at least one sensor may be mounted on the control module. The control module may be mounted within the motor compartment.

The control module may be mounted in a cooling air path of the motor. The control module may be affixed to the suction device. The control module may be affixed to the motor. The at least one sensor may be mounted in the suction chamber.

The one sensor may be a smoke sensor. The at least one sensor may be a carbon monoxide sensor.

In a fourth aspect the invention provides a method of sensing airborne contaminants. The method includes running a central vacuum unit of a central vacuum cleaning system to draw air through the unit, and sensing for contaminants within the central vacuum cleaning system.

The step of sensing may include sensing contaminants in a vacuum air path of the central vacuum cleaning system. The step of sensing may include sensing contaminants in an intake side of the vacuum air path. The step of sensing may include

sensing contaminants in an exhaust side of the vacuum air path. The step of sensing may include sensing contaminants in a cooling air path of the central vacuum cleaning system. The step of sensing may include sensing for contaminants in the cooling air path after a motor of the central vacuum cleaning system.

The step of sensing may include sensing for smoke. The step of sensing may include sensing for carbon monoxide.

Other aspects of the invention will be evident from the drawings and description herein.

BRIEF DESCRIPTION OF THE DRAWINGS

For a better understanding of the present invention and to show more clearly how it may be carried into effect, reference will now be made, by way of example, to the accompanying drawings which show the preferred embodiment of the present invention and in which:

FIG. 1 is a block diagram of a control circuit for a central vacuum cleaning system in accordance with a preferred embodiment of the present invention.

FIG. 2 is a cross-section of a dwelling incorporating the central vacuum cleaning system of FIG. 1.

DETAILED DESCRIPTION OF THE PREFERRED EMBODIMENT

Referring to FIG. 1, an example block diagram of a control circuit 1 for a central vacuum cleaning system 3 (see FIG. 2) is shown. The control circuit 1 has a controller 5 and a switch 7 for controlling line power 9 to the motor 10. The controller 5 and switch 7 form a control module 9 and are usually provided on a single printed circuit board 10a. The control module 9 typically includes an AC-DC power supply 11 for powering the controller 5 and other components. Optional indicators 13 are provided in the circuit 1 for communication with a user.

Airborne contaminant sensors indicated in this description generally as 15i, 15ii, etc., and different example contaminant type sensors as 15a, 15b form part of the control circuit 1. The sensors 15 provide input to the controller 5. The controller 5 may utilize inputs from the sensors 15 in any way desirable, for example, the controller 5 may control the motor 10 in accordance with input from the sensors 15. As a further example, the controller 5 may communicate with a user through the indicators 13 to provide an indication of sensed contaminant. An indication may be in the form of an audible or visible alarm. It may indicate the actual contaminant in text or icon form.

An airborne contaminant is a gas or minute particle that is inherently airborne. The vacuum cleaning system 3 may act as a conduit to a sensor 15. This configuration is to be distinguished from existing so-called "dirt sensors", which detect comparatively large particles that are airborne as a result of the airflow induced by a vacuum system. Such "dirt sensors" typically use acoustic or photoelectric means of detection. Airborne contaminants may include, for example, Combustible Gases, such as LP-Gas/Propane, Natural gas/Methane; General combustible gas, such as Hydrogen, Toxic Gases, Carbon monoxide, Ammonia, Hydrogen sulfide; Organic Solvents, such as Alcohol, toluene, xylene; Other volatile organic vapors, such as CFCs (HCFCs and HFCs), R-22, R-113, R-21-R-22, R-134a, R-22, Other refrigerant gases; Indoor Pollutants, such as Carbon dioxide, Air contaminants; Automobile Ventilation, such as Gasoline exhaust, Gasoline and diesel exhaust; Cooking Vapors, such as Volatile vapors from food (alcohol), Water vapors from food; radon; aller-

gens and other contaminants that may be found in an environment where a central vacuum cleaning system would be installed.

Sensor 15 may be a solid-state semi-conductor gas sensor. The resistance and capacitance of a semi-conductor gas sensor changes when reacting on specific gases. An example of such a sensor is a TGS 2600 from Figaro USA, Inc. of Glenview, Ill. This sensor detects hydrogen and carbon monoxide, which exist in cigarette smoke. Figaro USA, Inc., provides many other sensors that could be used.

Referring to FIG. 2, the sensors 15 may be mounted internally in a central vacuum unit 17 or externally. Externally mounted sensors 15i are preferably affixed, directly or indirectly, to the central vacuum unit 15 for ease of installation. Externally mounted sensors 15i affixed to the central vacuum unit would be useful particularly in sensing the environment in which the unit 17 is installed, typically a garage, basement, or utility room. In a garage or area where combustion appliances are operated, a carbon monoxide or other exhaust sensor 15a may be appropriate.

An internally mounted sensor 15ii may be mounted within a motor compartment 19 such that air conditions in the environment in which the unit 17 is installed may be sensed as cooling air is drawn through the unit 17. Also, a sensor 15ii mounted in the motor compartment 19 can sense more readily any contaminants being produced within the motor compartment 19, for example a smoke sensor 15b can sense smoke that indicates the beginning of a fire or overheating of the motor 10.

It may be preferable to directly mount the sensor 15ii in a cooling air path of the motor 10 to sense contaminants passing through or emanating from the motor 10. To sense contaminants emanating from the motor 10 then a sensor 15 mounted in the cooling air path would best be mounted in the cooling air path after cooling air passes through the motor 10.

The sensor 15 could be mounted within the vacuum air path of the cleaning system 3, either on the suction side 21 or the exhaust side 23, internally or externally.

An internal suction vacuum air path sensor 15iii may be mounted in a vacuum chamber 25 of the unit 17, ahead of or behind any filters. An internally mounted exhaust vacuum air sensor 15 may be mounted through the exhaust horn 29.

Externally mounted suction sensors 15iv or exhaust vacuum air sensor 15v can be mounted, for example, through intake pipes 31 or exhaust pipes 33 for vacuum air or through handle 34. In any of the above configurations the sensors 15 themselves may be mounted away from the area to be sensed with fluid connection provided to the area to be sensed, for example, through a tube or other conduit.

The sensor 15 may be controlled such that it is only activated while the motor 10 is activated. This would be appropriate where conditions may only be sensed when the motor 10 is in use. For example where operation of a vacuum cleaning system 3, and a resulting vacuum (particularly in "airtight homes"), may exacerbate conditions that lead to the generation of carbon monoxide from combustion appliances.

As an alternative example, the sensor 15 and the related portion of the control circuit 1 may be always on. This would be appropriate, for example, where conditions are dangerous, and may be sensed, independent of the use of the cleaning system, for example if smoke were to exist in the location in which the unit 17 is installed.

By mounting the sensor 15 to sense from the vacuum air path it is possible to sense remote locations. These locations may be sensed when the cleaner is in use. Alternatively, apertures 37 in remote wall valves 38 can allow air to be drawn through the pipes 31 to the sensor 15 when the vacuum

5

cleaning system is not in use at the wall valve **38** for cleaning. The apertures **37** could be always open and very small such that suction for cleaning would not be adversely affected.

Alternatively, the apertures **37** could be switchable between an open position and closed position. The open position used for sensing and the closed position used when the vacuum cleaning system **3** is in operation for cleaning. Switching could be performed manually. Alternatively, switching could be performed automatically when the cleaning system **3** is to be used in operation for cleaning. For example, switching of the aperture **37** could be wirelessly activated through a wireless radio frequency transmitter **43** connected to the controller **5** and a wireless radio frequency receiver **45** connected to the wall valve **38**.

The wall valve **38** could be switchable to open the vacuum air path if a sensor **15** senses a contaminant through an aperture **37**. This could allow for automatic remote sensing and evacuation of an area utilizing a central vacuum cleaning system **3**.

The controller **5** can be made up of discrete components to provide the logic functions described herein in a manner that would be evident to a person skilled in the art. Preferably, the controller **5** is a microprocessor with internal memory and one or more computer programs that together provide the logic functions described herein. The selection of an appropriate microprocessor will be a design choice depending on many factors such as cost, size, and number and complexity of functions desired.

The indicators **13** may be at the vacuum unit **17**, the hose handle **34**, or a remote location such as wall display **46**. Communication to the indicators **13** may be wired or wireless radio frequency. It may be through a remote controller **47** with radio frequency receive capability and, possibly, transmit capability. The sensor **15** and indicators **13** may be part of a contaminant sensing circuit, not shown, with its own controller and source of power to provide similar functionality to that previously described. For example, the separate contaminant sensing could be located entirely within the hose handle **34** to provide a direct alarm to a user.

It will be understood by those skilled in the art that this description is made with reference to the preferred embodiment and that it is possible to make other embodiments employing the principles of the invention which fall within its spirit and scope as defined by the following claims.

The invention claimed is:

1. A central vacuum unit for use in a central vacuum cleaning system, the unit comprising:

- a) a motor compartment,
- b) a vacuum chamber,
- c) a control circuit for controlling power to the motor,
- d) one or more airborne contaminant sensors for sensing contaminants within the unit, and
- e) one or more indicators for communicating with a user when a contaminant is sensed by one or more of the one or more airborne contaminant sensor.

2. A central vacuum cleaning system comprising:

- a) a central vacuum unit including a motor, a motor compartment, a vacuum chamber, a control circuit for controlling power to the motor,
- b) one or more airborne contaminant sensors for sensing airborne contaminants within the central vacuum cleaning system, and
- c) one or more indicators for communicating with a user when a contaminant is sensed by one or more of the one or more airborne contaminant sensors.

3. The system of claim **2** wherein at least one indicator is located on the central vacuum unit.

6

4. The system of claim **2** wherein at least one indicator is located on a vacuum hose handle.

5. The system of claim **2** wherein at least one indicator is located remotely from the central vacuum cleaning system.

6. The system of claim **5** wherein the at least one indicator is a wall display.

7. The system of claim **2** wherein at least one indicator is a display.

8. The system of claim **2** wherein at least one indicator is a sounder.

9. The system of claim **2** wherein at least one indicator is a LED array.

10. A method of communicating to a user a presence of one or more sensed airborne contaminants, the method comprising:

- a) running a central vacuum unit of a central vacuum cleaning system to draw air through the unit,
- b) sensing for contaminants within the central vacuum cleaning system, and
- c) communicating to the user the presence of the one or more sensed airborne contaminants using one or more indicators.

11. The method of claim **10** wherein a signal is sent to the one or more indicators in response to the sensed airborne contaminants.

12. The method of claim **11** wherein the signal is sent to the one or more indicators over a wired connection.

13. The method of claim **12** wherein the signal is sent to the one or more indicators over a wireless radio frequency.

14. The method of claim **13** wherein the signal sent to one or more indicators is through a remote controller that is capable of transmitting and receiving radio frequencies.

15. The method of claim **10** wherein the step of communicating comprises at least one indicator in the form of an audible alarm.

16. The method of claim **10** wherein the step of communicating comprises at least one indicator in the form of a visible alarm.

17. The method of claim **16** wherein the visible alarm indicates a sensed airborne contaminant by displaying text on a display.

18. The method of claim **16** wherein the visible alarm indicates a sensed airborne contaminant by displaying an icon on a display.

19. The method of claim **16** wherein the visible alarm indicates a sensed airborne contaminant using an LED array.

20. The method of claim **10** wherein sensing for contaminants comprises sensing for radon.

21. A contaminant sensing circuit for use in a central vacuum cleaning system, the circuit comprising:

- a) a controller,
- b) a power source,
- c) one or more airborne contaminant sensors for sensing airborne contaminants; and
- d) one or more indicators for communicating with a user, and

wherein the circuit is contained within a vacuum hose handle.

22. The circuit of claim **21** wherein at least one indicator is a display.

23. The circuit of claim **21** wherein at least one indicator is a sounder.

24. The circuit of claim **21** wherein at least one indicator is a LCD array.

25. The circuit of claim **21** wherein the one or more airborne contaminant sensors comprise a radon sensor.